

OPERATING, MAINTENANCE & PARTS MANUAL

ELECTRIC CHAIN HOIST



Before installing hoist, fill in the information below.

Model Number _____
Serial No. _____
Purchase Date _____
Voltage _____
Rated Load _____

RATED LOADS 1/4 TO 2 TONNES 250 KG TO 2000 KG

**Follow all instructions and warning for inspecting,
maintaining and operating this hoist.**

The use of any hoist presents some risk of personal injury or property damage. That risk is greatly increased if proper instructions and warnings are not followed. Before using this hoist, each operator should become thoroughly familiar with all warnings, instructions and recommendations in this manual. **Retain this manual for future reference and use.**

Forward this manual to operator. Failure to operate equipment as directed in manual may cause injury.



CM HOIST PARTS AND SERVICES ARE AVAILABLE IN THE UNITED STATES AND IN CANADA

PARTS FOR YOUR HOIST ARE AVAILABLE FROM YOUR LOCAL AUTHORIZED REPAIR STATION.
FOR THE NAME OF THE NEAREST PARTS OR SERVICE CENTER, VISIT OUR WEB SITE WWW.CMWORKS.COM
OR CALL OUR CUSTOMER SERVICE DEPARTMENT AT 1-800-888-0985.

SAFETY PRECAUTIONS

Each Entertainment-Lodestar Electric Hoist is built in accordance with the specifications contained herein and at the time of manufacture complied with our interpretation of applicable sections of the *American Society of Mechanical Engineers Code B30.16 "Overhead Hoists", the National Electrical Code (ANSI/NFPA 70), the Occupational Safety and Health Act, British Health Safety Executives, TUV and CE Directive. Since OSHA states the National Electrical Code applies to all electric hoists, installers are required to provide current overload protection and grounding on the branch circuit section in keeping with the code. Check each installation for compliance with the application, operation and maintenance sections of these articles.

The safety laws for elevators, lifting of people and for dumbwaiters specify construction details that are not incorporated in CM hoists. For such applications, refer to the requirements of applicable state and local codes, and the American National Safety Code for elevators, dumbwaiters, escalators and moving walks (ASME A17.1). Columbus McKinnon Corporation cannot be responsible for applications other than those for which CM equipment is intended.

*Copies of this Standard can be obtained from ASME Order Department, 22 Law Drive, Box 2300, Fairfield, NJ 07007-2300, U.S.A.



THIS SYMBOL POINTS OUT IMPORTANT SAFETY INSTRUCTIONS WHICH IF NOT FOLLOWED COULD ENDANGER THE PERSONAL SAFETY AND/OR PROPERTY OF YOUR SELF AND OTHERS. READ AND FOLLOW ALL INSTRUCTIONS IN THIS MANUAL AND ANY PROVIDED WITH THE EQUIPMENT BEFORE ATTEMPTING TO OPERATE YOUR LODESTAR HOIST.



⚠ WARNING
Usage of hoists that do not involve lifting of the load on the lower hook or using hoists in the hoist down position without special precaution may cause an accident resulting in injury and/or property damage.

⚠ WARNING
Improper operation of a hoist can create a potentially hazardous situation which, if not avoided, could result in <u>minor</u> or <u>moderate</u> injury. To avoid such a potentially hazardous situation, the operator shall:

⚠ WARNING
Improper operation of a hoist can create a potentially hazardous situation which, if not avoided, could result in <u>death</u> or <u>serious injury</u> . To avoid such a potentially hazardous situation, the operator shall:

1. **NOT** lift people.
2. **NOT** allow people on unsecured load without fall protection.
3. **NOT** exceed rated capacity of hoist.
4. **NOT** remove or obscure any capacity or warning label.
5. Check the supporting structure. The connection between the load hook and structure. The load itself and the connection between the hoist support and the load for their ability to withstand the loads imposed with an adequate design factor.
6. Tie off the load with auxiliary chains or cables before access to the area beneath the load is permitted. As an alternative, the system may be designed such that malfunction or failure of one hoist's load bearing components does not cause load loss and/or overloading of any other hoists in the system. Note that in such a system, hoist performance and function must be monitored visually or with use of load cells.
7. Read hoist manual and special instructions before installing and operating the hoist.

1. Maintain a firm footing or be otherwise secured when operating the hoist.
2. Check brake function by tensioning the hoist prior to each lift operation.
3. Use hook latches. Latches are to retain slings, chains, etc. under slack conditions only.
4. Make sure the hook latches are closed and not supporting any parts of the load.
5. Make sure the load is free to move and will clear all obstructions.
6. Avoid swinging the load or hook.
7. Make sure hook travel is in the same direction as shown on the controls.
8. Inspect the hoist regularly, replace damaged or worn parts, and keep appropriate records of maintenance.
9. Use CM parts when repairing the unit.
10. Lubricate load chain per instructions in this manual.
11. **NOT** use the hoist load limiting or warning device to measure load.
12. **NOT** use limit switches as routine operating stops. They are emergency devices only.
13. **NOT** allow your attention to be diverted when operating hoist.
14. **NOT** allow the hoist to be subjected to sharp contact with other hoists, structures, or objects through misuse.
15. **NOT** adjust or repair the hoist unless qualified to perform such adjustments or repairs.

Successful Theatrical Hoist Down Operation Requires the following actions:

At the loose end, maintain a minimum of 24 inches (61 cm) of chain freely hanging over the side of hoist.

Keep load chain well lubricated using Lubriplate® 10R Bar and Chain oil.

Do make sure hoist is phased properly and chain travel limits function properly.

If a chain container is used, inspect before each use for damaged, loose hardware and water drainage provisions. Make certain container attachment hardware has an adequate design factor of a minimum of 5 to 1. Also, make sure chain container is of sufficient capacity: chain in fully loaded container shall not exceed 75% of container height.

FOREWORD

This manual contains important information to help you properly install, operate and maintain your hoist for maximum performance, economy and safety.

Please study its contents thoroughly before putting your hoist into operation. By practicing correct operating procedures and by carrying out the recommended preventive maintenance suggestions, you will experience long, dependable and safe service. After you have completely familiarized yourself with the contents of this manual, we recommend that you carefully file it for future reference.

The information herein is directed to the proper use, care and maintenance of the hoist and does not comprise a handbook on the broad subject of rigging.

Rigging can be defined as the process of lifting and moving heavy loads using hoists and other mechanical equipment. Skill acquired through specialized experience and study is essential to safe rigging operations. For rigging information, we recommend consulting a standard textbook on the subject.

TABLE OF CONTENTS

Master Parts Depots And Service Centers	2
Safety Precautions	3
Foreword	4
General Information	
Specifications	5
Accessories	
Hook Suspensions	5
Latchlok Hooks	5
Installation	
Unpacking Information	6
Installing Suspension	6
Attaching Load Chain	7
Chain Stop Kit	8
Power Supply and Electrical Connections	8
Three Phase Hoist	8
Proper Phasing	9
Limit Switch Operation	10
Operating Instructions	
General	10
Safety Procedures	10-11
Inspection	
Inspection	11
Preventative Maintenance	11
Hook Inspection	11
Frequent Inspections	12
Periodic Inspections	12
Hook Remove Criteria	13
Inspecting the Load Chain	13
Maintenance	
Load-limiter	14
Hoist Lubrication	14
Gears	14
Bearings	14
Chain Guides, Liftwheel, and Lower Sheave Wheel	14
Load Chain	14
Limit Switch Adjustment	14
Upper Limit Switch	15
Lower Limit Switch	16
Electrical Data	17
Troubleshooting	18-19
Typical Wiring Diagrams	20-25

Assembly Instructions	
Swivel Hook Suspension	26
Lower Hook Block Pin	26
Removal and Installation of Load Chain	27
Cutting Chains	28
Ordering Instructions	29
Parts List	30-61
Lubricants	62
Recommended Spare Parts	62

LIST OF TABLES

Table	Title	Page
1	Lodestar Electric Chain Hoist Specs	5
2a-d	Recommended Torques	6-7
4	Minimum Frequent Inspections	12
5	Minimum Periodic Inspections	12
6a-b	Limit Switches	14-15
7	Electrical Data	17
8	Troubleshooting	18-19

LIST OF ILLUSTRATIONS

Figure	Table	Page
1	Hook Suspensions	5
2	Upper or Lower Latchlok Hook	5
7	Attaching Load Chain	7
8	Contact Block	7
12	Voltage Change Board	8
13	Locations of Components	8
14	Hook Inspection	13
15	Chain Wear areas	13
16	Chain Inspection	13
17	Chain Embossing	13
18	Limit Switches Models B, C & F	15
18A	Rotatable Limit Switches Models B, C & F	15
19	Limit Switches Models J, L, LL, R, RR & RRS	15
19A	Rotatable Limit Switch J, L, LL, R, RR & RRS	15
20	Typical Wiring Diagrams	20-25
21	Swivel Hook Suspensions	26

NOTE: This manual is for standard entertainment style hoists such as the BGV D8 and D8+ units. Additional information pertaining only to BVG C1 units is contained in manual supplements. However, the Installation, Inspection, Maintenance, Assembly, and Safety sections of this manual pertain to all models. The D8+ and C1 units contain dual brakes. The C1 units also contain secondary emergency limits and electronic over/under load protection. The load protection listed in this manual is only for the mechanical overload protection. See the manual supplements for operation of this additional equipment.



SPECIFICATIONS

The Lodestar Electric Chain Hoist is a highly versatile materials handling device that can be used to lift loads that are within its rated capacity. The mechanical features of these hoists include an alloy liftwheel, load-limiter, hardened steel chain guides, hardened steel load chain, hardened steel gear train, life-time lubrication, forged steel hooks, and lightweight aluminum frame. The electrical features included hoist-duty motor, rugged hoist brake, magnetic reversing contactor and voltage conversion board (dual voltage units).

Follow all instructions and warnings for inspecting, maintaining and operating this hoist.

The use of any hoist presents some risk of personal injury or property damage. That risk is greatly increased if proper instructions and warnings are not followed. Before using this hoist, each operator should become thoroughly familiar with all warnings, instructions, and recommendations in this manual.

Retain this manual for future reference and use.

Forward this manual to the hoist operator. Failure to operate the equipment as directed in the manual may cause injury.

Before putting hoist into service, fill in the information below. Refer to the hoist identification plate.

Model Number _____
 Serial Number _____
 Purchase Date _____
 Voltage _____
 Rated Load _____

TABLE 1. SPECIFICATIONS

Entertainment-Lodestar Electric Chain Hoists

Single Speed 230/460-3-60 or 220/380-3-50 or 220/415-3-50

Model	Maximum Capacity		Lifting Speed 50 Hz units		Lifting Speed 60 Hz units		Nominal Power at the Hook		Shortest Distance Between Hooks		Net Weight	
	Tonnes	kg	ft/min	m/min	ft/min	m/min	HP	KW	inches	mm	lbs	kg
B	1/4	250	13.3	4.06	16	4.88	1/4	0.186	16.9	429.3	63.0	28.6
C	1/4	250	26.7	8.13	32	9.75	1/4	0.186	16.9	429.3	71.0	32.2
F	1/2	500	13.3	4.06	16	4.88	1/2	0.373	16.9	429.3	70.0	31.8
J	1/2	500	26.7	8.13	32	9.75	1	0.746	18.1	459.7	122.6	55.6
L	1	1000	13.3	4.06	16	4.88	1	0.746	18.1	459.7	124.6	56.5
LL	1	1000	26.7	8.13	32	9.75	2	1.49	18.1	459.7	128.6	58.3
R	2	2000	6.7	2.03	8	2.44	1	0.746	25.8	655.3	147.3	66.8
RR	2	2000	13.3	4.06	16	4.88	2	1.49	25.8	655.3	147.3	66.8
RRS	2	2000	13.3	4.06	16	4.88	2	1.49	24.8	630	164	74.4

LODESTAR D8+

According to VPLT.SR2.0 and SQP2, D8 Plus chain hoists are used to lift loads during set-up and have the special characteristic of being able to hold loads at rest above people, without using a secondary component. The Lodestar D8+ has a minimum of 10:1 design factor, double brakes, and a clutch outside of the load path (when power is disconnected), per the requirements of the German Code of Practice, VPLT.SR2.0.

Model	Load Capacity	FEM Class	Starts/hr	Duty	Weight With Rigid Suspension and 10'ft(3m)lift		Chain Falls	Chain Size	Chain Minimum Breaking Strength		Chain Weight / Model Length of Lift	
	KG				lb	kg		mm x mm	lbf	kN	lb/ft	kg/m
F	250	2m	240	40%	79	35.8	1	6.35 x 18.91	10200	45.4	0.585	0.87
JJ	500	2m	240	40%	142	64.4	1	7.92 x 21.80	18000	80.1	0.94	1.40
L	650	2m	240	40%	135	61.2	1	7.92 x 21.80	18000	80.1	0.94	1.40
LL	500	2m	240	40%	142	64.4	1	7.92 x 21.80	18000	80.1	0.94	1.40
R	1300	2m	240	40%	158	71.7	2	7.92 x 21.80	18000	80.1	1.88	2.80
RR	1000	2m	240	40%	166	75.3	2	7.92 x 21.80	18000	80.1	1.88	2.80
RRS	1000	1Bm	150	25%	136	61.7	1	10.0 x 30.00	28250	125.7	1.45	2.16

ACCESSORIES

HOOK SUSPENSIONS

Swivel and rigid type hook suspensions (see Figure 1) are available for all Lodestar Electric Hoists. However, swivel type hook suspensions are normally recommended for most applications.



Figure 1. Hook Suspensions

LATCHLOK®HOOKS

CM's Latchlok hooks (see Figure 2) are available to replace the standard upper and lower hooks used on the Lodestar Electric Hoists.



Figure 2. Upper or Lower Latchlok® Hook

INSTALLATION

UNPACKING INFORMATION

When received, the hoist should be carefully inspected for damage which may have occurred during shipment or handling. Check the hoist frame for dents or cracks, the external cords for damaged or cut insulation, the control station for cut or damaged enclosure, and the load chain for nicks and gouges. If shipping damage has occurred, refer to the packing list envelope on the carton for claim procedure.

Before using the hoist, make sure the voltage change board is connected for the intended power supply the hoist is to be operated.

NOTE: See Electrical Installation instructions.

INSTALLING THE SUSPENSION (If Applicable)

A. Single Reeved Units For Models A, B,C,F,J,LL, L, & LL:

Remove the hook suspension and (2) suspension screws from the packaging. Place the suspension assembly into the recess on top of the hoist so that the adapter body follows the contour of the hoist. Insert the suspension screws through the holes in the adapter and hand thread these into the self-locking nuts enclosed in the hoist. The screws will turn freely into the nuts until the last 1/4" (6.35 mm) of travel, during which the resistance of the nut locking collar will be encountered.

WARNING

Use of impact tools (electric or pneumatic) may cause premature failure of attaching hardware.

Securely tighten the screws to the recommended seating torque (see Table 2) using a 12 point socket 3/8" for Models B, C, and F and 1/2" for Models J, L, LL, R and RR and 3/16" hex bit socket for Model RRS." following highlighted text.

For Model RRS: Remove the hook suspension, screw and locknut from the packaging. Slide the suspension assembly into the channel in the top of the hoist. Insert the locknut into the hex recess on the side of the suspension riser, insert the screw through opposite side and hand thread the screw into the self-locking nut.

B. Double Reeved Units:

Remove the hook suspension, (2) suspension screws, (1) dead end pin, (1) washer, and (1) cotter pin from the packaging. It should be noted that the suspension includes a dead end bolt and block for supporting the dead end of the load chain as shown in Figure 7. Place the suspension assembly into the recess on top of the hoist. The dead end block should project through the bottom of the hoist with the pin hole and slot aligned to the underside of the hoist as shown in Figure 7.

If these are not aligned as shown, lift the head of the bolt from the hex recess in the adapter and turn the bolt and block assembly and reseal the bolt head to obtain the proper alignment. Do not change the position of the dead end block on the bolt to attain this alignment.

Check the position of the pin hole in the dead end block to make sure it has not been disturbed from its factory setting. The distance from the top of the pin hole to the bottom of the hoist should not exceed 7/16" (11.11 mm) for the Models R and RR. If the distance is not correct, adjust the position of the dead end block to obtain the proper distance (see Page 46).

Now, insert the suspension screws through the holes in the adapter and hand thread these into the self-locking nuts enclosed in the hoist frame. The screws will turn freely into the nut until the last 1/4" (6.35mm) of travel during which the resistance of the nut locking collar will be encountered. Securely tighten the screws to the recommended seating torque (see Table 2) using a 12 point socket 3/8" for Models B, C & F and 1/2" for Models J, L,LL, R and RR.

The dead end of the load chain is temporarily positioned (a few links from the end) by a wire tie. Do not remove this tie before attaching the chain to the dead end block. (See Fig.7).

Table 2a. Torque Specification: All Models

Fastener	Fastener Description	Tool Required	*Recommended Seating Torque	
			ft-lbf	N-m
Brake End cover	1/4"-20 Socket Head Cap Screw	3/16" Hex Driver	4.2 - 5.0	5.7 - 6.8
Motor End Cover	1/4"-20 Socket Head Cap Screw	3/16" Hex Driver	4.2 - 5.0	5.7 - 6.8
Reversing contactor Connecting Screws-1ø	Terminal Clamp Screw	Phillips no. 2 or 3/16" slotted head screwdriver	0.6 - 1.0	0.8 - 1.3
Reversing contactor Connecting Screws-3ø	Terminal Clamp Screw	Phillips no. 2 or 3/16" slotted head screwdriver	0.6 - 1.0	0.8 - 1.3
Limit Switch Guide Screws	#10-24 Button Head Socket Cap Screw	5/32" Hex Driver	1.7 - 2.1	2.3 - 2.8
#6-32 Button Head Screw for Contactor Plate Applications	#6-32 Button Head Socket Cap Screw	5/64" Hex Driver	0.7 - 0.8	0.9 - 1.1
#8-32 Button Head Screw for Contactor Plate Applications	#8-32 Button Head Socket Cap Screw	3/32" Hex Driver	1.1 - 1.4	1.5 - 1.9
#10-24 Button Head Screw for Contactor Plate Applications	#10-24 Button Head Socket Cap Screw	5/32" Hex Driver	1.7 - 2.1	2.3 - 2.8
1/4-20 Button Head Screw for Miscellaneous Applications	1/4-20 Button Head Socket Cap Screw	5/32" Hex Driver	4.2 - 5.0	5.7 - 6.8
Cord Grips	TBD	TBD	X - X	X - X

Table 2b. Torque Specification: Models B-F

Fastener	Fastener Description	Tool Required	*Recommended Seating Torque	
			ft-lbf	N-m
Motor Housing / Gear Housing / Back Frame Screws	1/4"-20 Socket Head Cap Screw	3/16" Hex Driver	7.9 - 8.3	10.7 - 11.3
Lift-Wheel Nut	1"-12 Hex Nut	1-1/2" - 6 or 12 Point Socket	55.0 - 60.0	74.6 - 81.3
Brake Attaching Screws	1/4-20 Button Head Socket Cap Screw	5/32" Hex Driver	4.2 - 5.0	5.6 - 6.8
Brake Armature Mounting Screws	M5 Socket Head Cap Screw	4mm Hex Driver	4.0 - 4.7	5.4 - 6.4
Contactor Plate Mounting Nuts	1/4-20 Hex Nut	7/16" - 6 or 12 Point Socket	2.0 - 2.5	2.7 - 3.4
Suspension Adapter Screws	3/8"-16 - 12-Point Cap Screw	3/8" - 12 Point Socket	35.0 - 45.0	47.5 - 61.0
"Lower Hook Block Screws	1/4"-20 Socket Head Cap Screw	3/16" Hex Driver	5.0 - 5.8	6.8 - 7.9
"Double Reeved"	1/4"-20 Socket Head Cap Screw	3/16" Hex Driver	5.0 - 5.8	6.8 - 7.9
Loose End Screw	1/4"-20 Socket Head Cap Screw	3/16" Hex Driver	4.2 - 5.0	5.6 - 6.8
Chain Stop Screw	1/4"-20 Socket Head Cap Screw	3/16" Hex Driver	5.0 - 5.8	6.8 - 7.9

Table 2c. Torque Specification: Models J-RR

Fastener	Fastener Description	Tool Required	*Recommended Seating Torque	
			ft-lbf	N-m
Motor Housing / Gear Housing / Back Frame Screws	5/16"-18 Socket Head Cap Screw	1/4" Hex Driver	14.2 - 15.0	19.2 - 20.3
Lift-Wheel Nut	1-1/8"-12 Hex Nut	1-11/16" - 6 or 12 Point Socket	85.0 - 90.0	115.2 - 122.0
Brake Attaching Screw	5/16"-18 Socket Head Cap Screw	1/4" Hex Driver	4.2 - 5.0	5.6 - 6.8
Brake Armature Mounting Screws	M6 Socket Head Cap Screw	5mm Hex Driver	7.1 - 7.9	9.6 - 10.7
Stator Mounting Screws	1/4"-20 Hex Cap Screw	7/16" - 6 or 12 Point Socket	4.2 - 5.0	5.6 - 6.8
Suspension Adapter Screws	1/2"-20 12-Point Cap Screw	1/2" - 12 Point Socket	70.0 - 80.0	94.9 - 108.5
"Lower Hook Block Screws	5/16"-18 Socket Head Cap Screw	1/4" Hex Driver	10.0 - 11.3	13.6 - 15.3
"Double Reeved"	5/16"-18 Socket Head Cap Screw	1/4" Hex Driver	10.0 - 11.3	13.6 - 15.3
Loose End Screw	5/16"-18 Socket Head Cap Screw	1/4" Hex Driver	8.0 - 10.0	10.8 - 13.6
Chain Stop Screw	1/4"-20 Socket Head Cap Screw	3/16" Hex Driver	5.0 - 5.8	6.8 - 7.9

Table 2d. Torque Specification: Model RRS

Fastener	Fastener Description	Tool Required	*Recommended Seating Torque	
			ft-lbf	N-m
Main Frame/Intermediate Frame/Back Frame Screws	5/16"-18 Socket Head Cap Screw	1/4" Hex Driver	14.2 - 15.0	19.2 - 20.3
3rd Pinion Nut	1-1/8"-12 Hex Nut	1-11/16" - 6 or 12 Point Socket	85.0 - 90.0	115.2 - 122.0
Chain Chute Pin Set Screw Torque	1/2-13 Hex Recess Set Screw	1/4" Hex Driver	11.7 - 13.3	15.8 - 18.1
Brake Attaching Screw	5/16"-18 Socket Head Cap Screw	1/4" Hex Driver	4.2 - 5.0	5.6 - 6.8
Brake Armature Mounting Screws	M6 Socket Head Cap Screw	5mm Hex Driver	7.1 - 7.9	9.6 - 10.7
Stator Mounting Screws	1/4"-20 Hex Cap Screw	7/16" - 6 or 12 Point Socket	4.2 - 5.0	5.6 - 6.8
Suspension Retainer Screw	1/4"-20 Socket Head Cap Screw	3/16" Hex Driver	4.2 - 5.0	5.6 - 6.8
Chain Container Bracket Mounting Screws	9/16"-18 Socket Head Cap Screw	7/16" Hex Driver	20.0 - 50.0	27.1 - 67.8
Chain Stop Screws	5/16"-18 Socket Head Cap Screw	1/4" Hex Driver	10.0 - 13.0	13.6 - 17.6

*All Torque values are for clean, dry fasteners. DO NOT apply oil or any other lubricant to the fastener threads

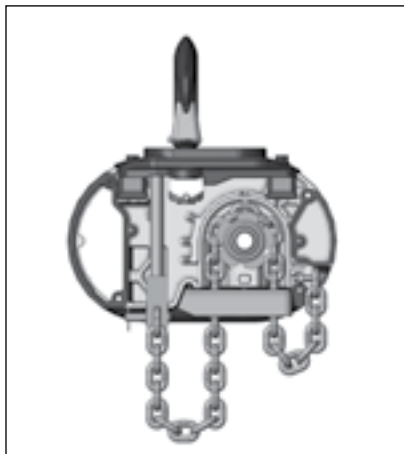

Figure 7. Attaching Load Chain Double Reeved Models

1. Dead end block
2. Suspension assembly
3. Suspension self-locking nut
4. Dead end bolt
5. Dead end link
6. Chain guide
7. Lift-wheel
8. Gear housing
9. Loose end screw
10. Loose end link
11. Loose end

(Do not order parts by these numbers. See parts list)

WARNING

Using other than CM supplied high strength suspension screws to attach the suspension adapter to the hoist may cause the screws to break and allow the hoist and load to fall.

TO AVOID INJURY:

Use only the CM supplied suspension screws to attach the suspension to the hoist and hand torque these screws to the recommended seating torque as specified in tables 2a and 2b.

DO NOT apply any type of lubricant to the threads of these screws. Lubricating the threads will reduce the effort to seat the screws and as a result, tightening the screws to the above recommended torque may break the screw, damage the suspension adapter, strip the nuts and/or damage the hoist frame.

SUSPENSION BOLT SHOULD BE REPLACED ANY TIME THE SUSPENSION IS REMOVED FROM THE HOIST.

ATTACHING LOAD CHAIN

The Double Reeved Units are shipped with the dead end of the load chain temporarily connected to the bottom of the hoist by a wire tie (1) as shown in Figure 7. The wire tie is located a few links from the end of the chain, and it should not be removed until the chain is to be attached to the dead end block (2). To attach the chain to the dead end block, proceed as follows:

1. Suspend the hoist from an adequate support.
2. The hoist is shipped with the dead end of the load chain temporarily positioned a few links from the end by a wire tie (1) as shown in Figure 7. Do not remove this wire tie until the chain is secured.
3. Do not remove the wire ties from the load chain at this time.

See page 29 for further instructions.

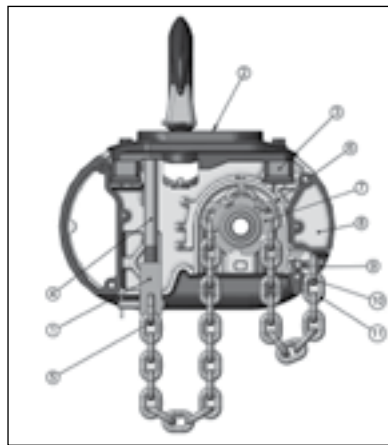
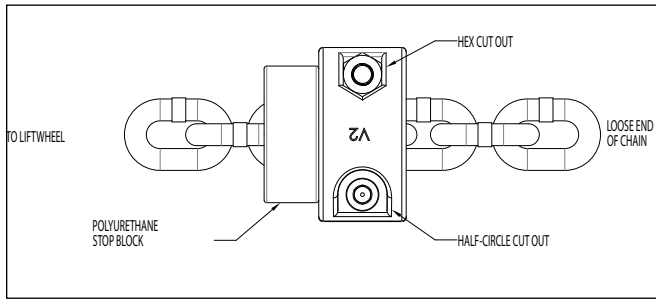

Figure 8. Contact Block Used On Models R & RR.

CHAIN STOP KIT



Place polyurethane stop block over loose end of chain and slide past desired spot that the chain stop is to be located. Place one half of chain stop on chain. Then place other half on top of the first half of chain stop. (Note: Be sure that the half circle cut out side of one stop block half is aligned with hex cut out side.) Place one (1) nut into hex cutout insert one (1) screw with one (1) lock washer through hole opposite nut and loosely tighten. Repeat for second connection. Tighten both screw connections to ensure that they do not come loose.

EXTERNAL CHAIN PLATE

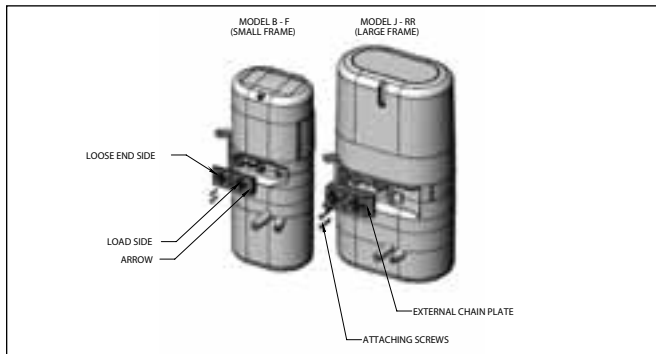

Models	Kit Code
B-F	10001440
J-RR	10001441

POWER SUPPLY AND ELECTRICAL CONNECTIONS

The hoist should be connected to a branch circuit which complies with the requirements of the National Electrical Code and applicable local codes.

It is recommended, especially for a single phase hoist with a (1) horsepower motor (.75 Kilowatts), that a line of adequate capacity be run directly from the power supply to the hoist to prevent problems with low voltage and circuit overloads.

For grounding of the hoist, the power cord includes a grounding conductor (green yellow, G-Y). Before connecting the hoist to the power supply, check that the power to be used agrees with the position of voltage change plug on the voltage change board. The nominal hoist voltage rating corresponding to the voltage range given on hoist identification plate is:

Dual Voltage Units					
Low	Range	Nominal Volts	High	Range	Nominal Volts
	220-240	230		380-415	400
			440-460	460	

THREE PHASE HOIST

Unless ordered on a special basis, all single speed/dual voltage (230/460-3-60, 220/380-3-50 and 220/415-3-50) North American hoist are factory arranged to operate on 460-3-60 (or 380-3-50 or 415-3-50). Dual voltage D8 and D8+ units are factory arranged to operate at 230-3-6 (220-3-50). However, a voltage change board is provided to easily and quickly change from 460 to 230 (or 380 to 220 or 415 to 220) volt operation. The voltage change board shown in Figure 12 is located in the hoist as shown in Figure 13.

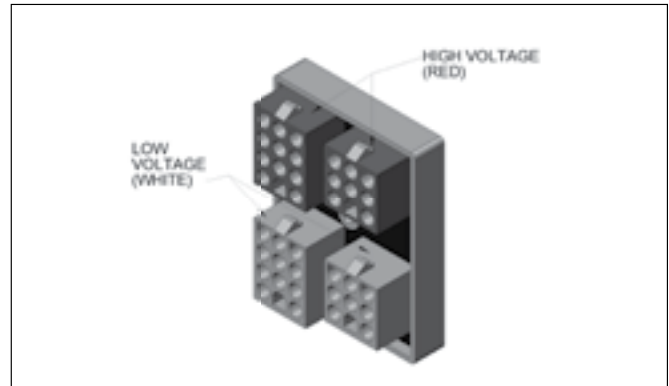

Figure 12. Voltage Change Board

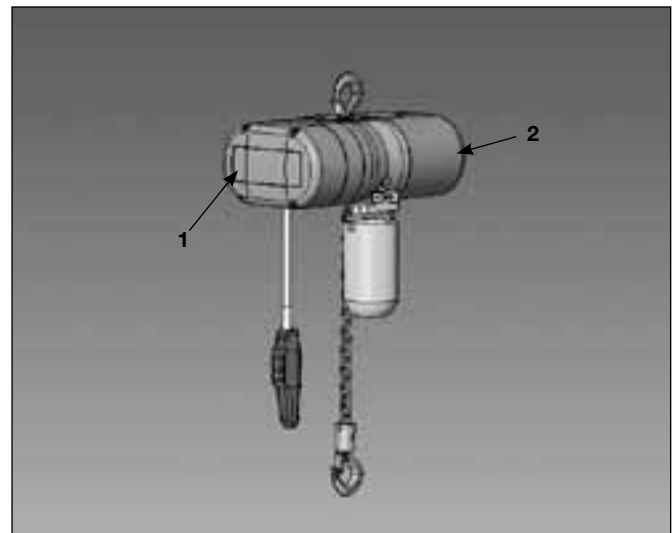

Figure 13. Location of Components

Voltage change board is located under back frame cover (1) for Models B, C & F and under motor housing cover (2) for Models J, L, LL, R and RRS.

The voltage change board is color coded to indicate high and low volt connections. Connecting the 9 and 12 pin plugs into the "Red" voltage change board receptacles will connect the hoist for high voltage (380-3-50, 415-3-50 or 460-3-60). To change the hoist voltage to low voltage (208-3-60, 220-3-50 or 230-3-60) simply remove the 9 and 12 pin plugs from the "Red" receptacles and insert same into the "White" receptacles located on the voltage change board.

Be sure to make a notation of the new hoist voltage on the tag attached to the power cord. Direct Control hoist are voltage specific and factory wired at 460-3-60 (380-3-50 or 415-3-50).

PROPER PHASING

Since the motor in a three phase hoist can rotate in either direction, depending on the manner in which it is connected to the power supply, the direction of hook movement must be checked prior to each usage.

NOTE: Serious damage can result if the hook is run to the upper or lower limit of travel with the hook operating in a direction opposite to that indicated by the control station. Therefore, proceed as follows:

1. Make temporary connections at the power supply.
2. Operate ↑ (UP) control momentarily. If hook raises, connections are correct and can be made permanent.
3. If hook lowers, it is necessary to change direction by inter-changing the Grey lead and the Black lead of hoist power supply. Under no circumstances should the internal wiring of the control device or hoist be changed to reverse hook direction. The wiring is inspected and tested before leaving the factory.

Do not force the Lodestar Load-limiter to compensate for improperly adjusted limit switches or reverse voltage phasing.

WARNING

Allowing the hook block to run into the bottom of the hoist when raising a load or allowing the chain to become taut between the loose end screw and the frame when lowering a load may break the chain and allow the load to drop.

TO AVOID INJURY:

Do not allow the hook block to contact the bottom of the hoist or the loose end chain to become taut.

CHECKING FOR TWIST IN LOAD CHAIN Models R, RR

The best way to check for this condition is to run the lower hook, without a load, up to within about 2 feet (.61 Meters) of hoist. If the dead end of the chain has been properly installed, a twist can occur only if the lower hook block has been capsized between the strands of chain. Reverse capsize to remove twist.

CHECKING FOR ADEQUATE VOLTAGE AT HOIST

The hoist must be supplied with adequate electrical power in order to operate properly. For proper operation, the voltage, (measured at the hoist end of the standard power cord with the hoist operating in the ↑, up direction with full load) must be as indicated in the table below.

NOMINAL VOLTAGE	MINIMUM RUNNING VOLTAGE	MINIMUM STARTING VOLTAGE
115-1-60	104	98
230-1-60	207	196
230-3-60	187	-
460-3-60	396	-
220-3-50	198	-
380-3-50	365	-
415-3-50	399	-

SIGNS OF INADEQUATE ELECTRICAL POWER

(LOW VOLTAGE) ARE:

- Noisy hoist operations due to brake and/or contactor chattering.
- Dimming of lights or slowing of motors connected to the same circuit.
- Heating of the hoist motor and other internal components as well as heating of the wires and connectors in the circuit feeding the hoists.
- Failure of the hoist to lift the load due to motor stalling.
- Blowing of fuses or tripping of circuit breakers.

To avoid these low voltage problems, the hoist must be connected to an electrical power supply system that complies with the National Electrical Code and applicable local codes. This system must also provide (slow blow fuses or inverse-time type circuit breakers) and provisions for grounding the hoist.

WARNING

Failure to properly ground the hoist presents the danger of electric shock.

TO AVOID INJURY:

Permanently ground the hoist as instructed in this manual.

Low voltage may also be caused by using an undersized cord and/or connectors to supply power to the hoist. The following chart should be used to determine the size wires in the extension cord in order to minimize the voltage drop between the power source and the hoist.

LENGTH OF EXTENSION CORD	THREE PHASE HOISTS	SINGLE PHASE HOIST
	MINIMUM WIRE SIZE	MINIMUM WIRE SIZE
UP TO 50 FEET (15.2 m)	#16 AWG (1.5 mm ²)	#14 AWG (2.5 mm ²)
80 FEET (24.4 m)	#16 AWG (1.5 mm ²)	#12 AWG (4 mm ²)
120 FEET (36.7 m)	#14 AWG (2.5 mm ²)	#10 AWG (6 mm ²)
200 FEET (61.0 m)	#14 AWG (2.5 mm ²)	Contact Factory
For runs beyond 200 Ft (61 m) contact factory.		

WARNING

Failure to provide a proper power supply system for the hoist may cause hoist damage and offers the potential for a fire.

TO AVOID INJURY:

Provide each hoist with a 20 amp, minimum, overcurrent protected power supply system per the National Electrical Code and applicable local codes as instructed in this manual.

Remember, operation with low voltage can void the CM repair/replacement policy. When in doubt about any of the electrical requirements, consult a qualified electrician.

WARNING

TO AVOID INJURY:

Always disconnect the power cord from the power supply system and lockout/tagout disconnecting means before servicing the hoist. Working in or near exposed energized electrical equipment presents the danger of electric shock.

CHECKING LIMIT SWITCH OPERATION IF HOIST IS EQUIPPED

With hoists that are equipped with an adjustable screw limit switch, the limit switch will automatically stop the hook at any predetermined point when either hoisting or lowering.

⚠ WARNING
Failure to properly ground the hoist presents the danger of electric shock.
TO AVOID INJURY:
Permanently ground the hoist as instructed in this manual.

Operate hoist over the entire length of its rated lift, checking upper and lower limit switches for correct operation as follows:

1. Press (UP) control and raise the lower hook until top of hook block is about 12 inches (305 mm) below the hoist.
2. Cautiously continue raising the hook until the upper limit switch stops the upward motion. The upper limit switch is set at the factory to stop the hook block 8 links from the bottom of all hoists.
3. If adjustment is necessary, see page 15.
4. Press(DOWN) control and cautiously lower hook until lower limit switch stops the downward motion. On hoist operated in the motor down orientation, maintain a minimum of 24" (610mm) of chain freely hanging over the side of the hoist.
5. If adjustment is necessary, see page 15.

NOTE: If the hoist is equipped with a chain container/bag, reset the upper and lower limit switches as indicated on page 15.

Under no condition should the hook block or load be permitted to come in contact with the chain container/bag. If contact is made, the function of the chain container can be interfered with and its fasteners imperiled.

NOTE: When chain bag is filled to capacity the bag must be no more than 75% filled.

OPERATING INSTRUCTIONS

GENERAL

1. The Load-limiter is designed to slip on an excessive overload. An overload is indicated when the hoist will not raise the load. Also, some clutching noise may be heard if the hoist is loaded beyond rated capacity. Should this occur, immediately release the ↑ (UP) control to stop the operation of the hoist. At this point, the load should be reduced to the rated hoist capacity or the hoist should be replaced with one of the proper capacity. When the excessive load is removed, normal hoist operation is automatically restored.

CAUTION: The Load-limiter is susceptible to overheating and wear when slipped for extended periods. Under no circumstance should the clutch be allowed to slip for more than a few seconds.

Due to the above, a hoist equipped with a Load-limiter is not recommended for use in any application where there is a possibility of adding to an already suspended load to the point of overload. This includes dumbwaiter (*see below) installations, containers that are loaded in mid-air, etc.

(* Refer to limitations on Page 3 concerning dumbwaiter applications.

SAFE OPERATING INSTRUCTIONS AND PROCEDURES

For safety precautions and a list of Do's and Do Not's for safe operation of hoists, refer to page 3.

1. Permit only competent personnel to operate unit.
2. When preparing to lift a load, be sure that the attachments to the hook are firmly seated in hook saddle. Avoid off center loading of any kind, especially loading on the point of hook.

3. Do not allow the load to bear against the hook latch. The latch is to help maintain the hook in position while the chain is slack before taking up slack chain.
4. Do not wrap the load chain around the load and hook onto itself as a choker chain. Doing this will result in:
 - a. The loss of the swivel effect of the hook which could result in twisted chain and a jammed lift wheel.
 - b. The upper limit switch, if so equipped, is by-passed and the load could hit the hoist.
 - c. The chain could be damaged at the hook.
5. Before lifting load, check for twists in the load chain. On double reeved units a twist can occur if the lower hook block has been capsized between the strands of chain. Reverse the capsize to remove twist.
6. On single reeved chain hoist used in conjunction with head blocks and ground support systems, check for twists between the hoist and head block. Twisted load can result in a jammed liftwheel.
7. Do not use this or any other overhead materials handling equipment for lifting persons.
8. Do not load hoist beyond the rated capacity shown on hoist identification plate or on the hoist motor housing cover or hoist back frame cover. Overload can cause immediate failure of some load-carrying part or create a defect causing subsequent failure at less than rated capacity. When in doubt, use the next larger capacity CM Lodestar Hoist.
9. Warn personnel of your intention to lift a load in the area. Tie off the load with auxiliary chains or cables before access to the area beneath the load is permitted.
10. Do not operate hoist at unusual extremes of ambient temperatures above 150° F (60° C) or below 0° F (-17° C).
11. **Removing Hoist From Road Case and Operating on Stage**

Motors can be removed from the road case by manual lifting, or rigged while still in the case and power out.

Manual Lifting – It is recommended that two people be used to the lift the hoist from the road case. The motor can be lifted by grasping the handles (if fitted), the end covers, or the load chain. Never pull on the electrical cable(s) even if equipped with an external strain relief.

When placed on the floor the motor should be positioned on its side with the chain pulled away to allow the chain to enter the hoist without jamming if the hoist is to be operated.

⚠ WARNING
Never operate a Lodestar motor while standing on its end as in the figure to the right.
The motor may tip over and damage the casing, but more importantly it will cause the Lodestar to "drag" against its brake putting extra strain on the electric motor.

When running chain "in" the motor should be laid on its side on the ground / stage with the chain stretched out along the ground. The "dead" end side of the motor should be on the floor. With the motor in this position, gravity will hold the chain and allow it to run freely through the motor and help unravel any twists and prevent chain jam.



When running chain “out”, the same principal should be adopted but this time with the “dead” end side of the motor facing up. Again, this will prevent twists causing chain jam.

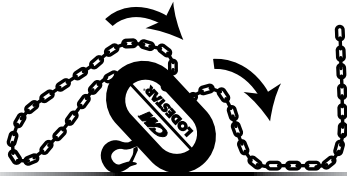

When using Lodestar motors with 2 chain falls (for example on Model R or RR) you should check for twists in the chain. The best way to check for this condition is to run the lower hook up (without load) to within about 24 inches (600mm) of the motor when any twists will become apparent, if the chain has been properly installed a twist can only occur if the lower block has been capsized between the strands of chain – reverse capsize to remove twists.

- Before moving a truss use a verbal warning such as “truss moving”. Always “bump” the motors before lifting or lowering. This will do 2 things:
 - It will act as a warning to people around that the rig is about to move should they not have heard your warning.
 - Any problem with rigging or reeving will show up in this “bumping through” – always leave enough chain to “bump” without running out of chain.
- Always have one person in charge of moving the rig, but as many “spotters” as necessary to watch any motors the main person cannot see.
- When replacing the motor in the road case, the chain should be run to the lower limit then operated in the up direction for about 6 (152 mm) to 8 (203 mm) inches. This should be done because:
 - The ceiling height may be lower in this venue than the next. If you run all the chain out, this assures enough chain for the rigger to hit the point in the next venue regardless of the height.
 - Running off the lower limit prevents any damage to the micro switch due to vibration as the motor travels to the next venue.

⚠ WARNING

Allowing the load to bear against the hook latch and/or hook tip can result in loss of load.

TO AVOID INJURY:

Do not allow the load and/or attachments to bear against the hook latch and/or hook tip. Apply load to hook bowl or saddle only.

12. Take up a slack load chain carefully and start load easily to avoid shock and jerking of hoist load chain. If there is any evidence of overloading, immediately lower the load and remove the excess load.
13. When lifting, raise the load only enough to clear the floor or support and check to be sure that the attachments to the hook and load are firmly seated. Continue lift only after you are assured the load is free of all obstructions.
14. Do not allow the load to swing or twist while hoisting.
15. Never operate the hoist when flammable materials or vapors are present. Electrical devices produce arcs or sparks that can cause a fire or explosion.
16. **STAY ALERT!** Watch what you are doing and use common sense. Do not use the hoist when you are tired, distracted or under the influence of drugs, alcohol or medication causing diminished control

INSPECTION

To maintain continuous and satisfactory operation, a regular inspection procedure must be initiated to replace worn or damaged parts before they become unsafe. Inspection intervals must be determined by the individual application and are based on the type of service to which the hoist will be subjected.

The type of service to which the hoist is subjected can be classified as “Normal”, “Heavy”, or “Severe”.

Normal Service: Involves operation with randomly distributed loads within the rated load limit, or uniform loads less than 65 percent of rated load for not more than 25 percent of the time.

Heavy Service: Involves operating the hoist within the rated load limit which exceeds normal service.

Severe Service: Normal or heavy service with abnormal operating conditions or constant exposure to the elements of nature.

Two classes of inspection - frequent and periodic - must be performed.

Frequent Inspections: These inspections are visual examinations by the operator or other designated personnel. Records of such inspections are not required. The frequent inspections are to be performed monthly for normal service, weekly to monthly for heavy service, and daily to weekly for severe service, and they should include those items listed in Table 4.

Periodic Inspections: These inspections are visual inspections of external conditions by an appointed person. Records of periodic inspections are to be kept for continuing evaluation of the condition of the hoist. Periodic inspections are to be performed yearly for normal service, semi-annually for heavy service and quarterly for severe service, and they are to include those items listed in Table 5.

CAUTION: Any deficiencies found during inspections are to be corrected before the hoist is returned to service. Also, the external conditions may show the need for disassembly to permit a more detailed inspection, which, in turn, may require the use of nondestructive type testing.

PREVENTIVE MAINTENANCE

In addition to the above inspection procedure, a preventive maintenance program should be established to prolong the useful life of the hoist and maintain its reliability and continued safe use. The program should include the periodic and frequent inspections with particular attention being paid to the lubrication of the various components using the recommended lubricants (see page 14).

HOOK INSPECTION

Hooks damaged from chemicals, deformations or cracks, or any visibly apparent bend or twist from the plane of the unbent hook, excessive opening or seat wear must be replaced. Also, hooks that are opened and allow the latch to not engage the tip must be replaced. Any hook that is twisted or has excessive throat opening indicates abuse or overloading of the unit. Inspect other load sustaining parts, hook block screws, load pins and hook block bodies for damage.

On latch type hooks, check to make sure that the latch is not damaged or bent and that it operates properly with sufficient spring pressure to keep the latch tightly against the tip of the hook and allow the latch to spring back to the tip when released. If the latch does not operate properly, it should be replaced. See Figure 14 to determine when the hook must be replaced.

SUSPENSION BOLT SHOULD BE REPLACED ANY TIME THE SUSPENSION IS REMOVED FROM THE HOIST.

Table 4. Minimum Frequent Inspections			
TYPE OF SERVICE			ITEM
Normal	Heavy	Severe	
Monthly	Weekly to Monthly	Daily to Weekly	a) Brake for evidence of slippage.
			b) Control functions for proper operation.
			c) Hooks for damage, cracks, twists, excessive throat opening, latch engagement and latch operation - see page 13.
			d) Load chain for adequate lubrication, as well as for signs of wear, damaged links or foreign matter - see page 13.
			e) Load chain for proper reeving and twists.

Table 5. Minimum Periodic Inspections			
TYPE OF SERVICE			ITEM
Normal	Heavy	Severe	
Yearly	Every 6 Months	Every 3 Months	a) All items listed in Table 4 for frequent inspections.
			b) External evidence of loose screws, bolts or nuts.
			c) External evidence of worn, corroded, cracked or distorted hook block, suspension screws, gears, bearings and dead end block and chain pin.
			d) External evidence of damage to hook retaining nut and pin. Also check the upper suspension adapter making sure it is fully seated in the hoist frame and that both screws are tight.
			e) External evidence of damage or excessive wear of the liftwheel and hook block sheave chain pockets. Widening and deepening of the pockets may cause the chain to lift-up in the pocket and result in binding between liftwheel and chain guides or between the sheave and hook block. Also, check the chain guide for wear or burring where the chain enters the hoist. Severely worn or damaged parts should be replaced.
			f) External evidence of excessive wear of brake parts, and brake adjustment - see page 14.
			g) External evidence of pitting or any deterioration of contactor contacts. Check the operation of the control station making sure the buttons operate freely and do not stick in either position.
			h) Inspect the electrical cords and cables and control station enclosure for damaged insulation.
			i) Inspect trolley trackwheels for external wear on tread and flange and for wear on internal bearing surfaces as evidenced by a looseness on the stud. Suspension components for damage, cracks, wear and operation. Also check suspension adapter screws for proper tightness - see page 6.
			j) Inspect the loose end link, loose end screw and dead end block on double reeved units. Replace worn or distorted parts.
			k) Inspect the suspension lug or hook for excess free play or rotation. Replace worn parts as evidenced by excess free play or rotation.
l) Inspect for signs of lubricant leaks at the gasket between the gear housing and back frame. Tighten screws holding back frame to gear housing. If leak persists, repack housing and gears with grease and install a new gasket.			

HOOK REMOVE CRITERIA

Based on ASME B30.10, hooks shall be removed from service if damage such as the following is visible and shall only be returned to service when approved by a qualified person:

1. Missing or illegible rated load identification or illegible hook manufacturers' identification or secondary manufacturer's identification.
2. Excessive pitting or corrosion. c. Cracks, nicks, or gouges.
3. Wear--any wear exceeding 10% of the original section dimension of the hook or its load pin.
4. Deformation--any visibly apparent bend or twist from the plane of the unbent hook.
5. Throat opening--any distortion causing an increase in the throat opening of 5% not to exceed 1/4" (6mm).
6. Inability to lock- any self-locking hook that does no lock.
7. Inoperative latch any damaged latch or malfunctioning latch that does not close the hook's throat.
8. Thread wear, damage, or corrosion.
9. Evidence of excessive heat exposure or unauthorized welding.
10. Evidence of unauthorized alterations such as drilling, machining, grinding, or other modifications.

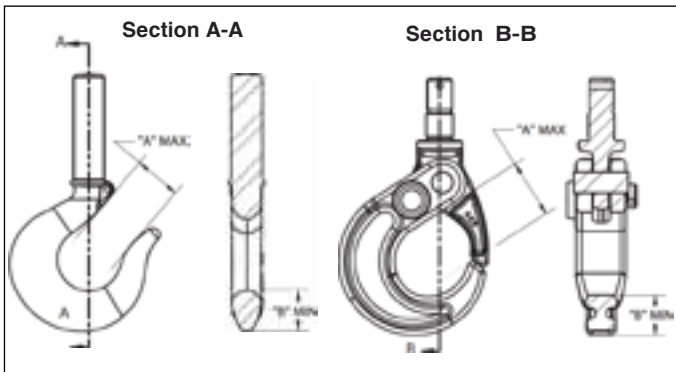

Figure 14. Hook Inspection

Models	Latch Type Hook		Latchlok® Hook	
	"A" Max	"B" Min	"A" Max	"B" Min
B, C & F	1.19" (30.2mm)	.91" (23.1mm)	1.48" (37.7mm)	.75" (18.8mm)
J, L & LL	1.31" (33.3mm)	1.08" (27.5mm)	1.48" (37.7mm)	.75" (18.8mm)
R, RR & RRS	1.50" (38.1mm)	1.43" (36.2mm)	1.92" (48.8mm)	.94" (23.9mm)

INSPECTING THE LOAD CHAIN:

The chain must be inspected at regular intervals, with a minimum of once annually. As the frequency of use increases, the time intervals between inspections must be reduced. During inspection, the chain link must be examined along their entire length, including the hidden parts. If the lifting equipment is frequently used with a constant lifting distance or in other words the switch from upward to downward often takes place in the same area, a particularly thorough inspection and lubrication is required in that area. Worn chain can also be an indication of worn hoist components. For this reason, the hoist's chain guides, hook blocks and liftwheel (sprocket) should be examined for wear and replaced as necessary when replacing chain.

1. Check to see if chain is dirty or poorly lubricated.
2. Clean the chain with a non-caustic/non-acid type solvent and make a link by link inspection for wear or cracks in the links, twisted or deformed links. Chain with any one of these defects must be replaced.

3. Slack the portion of the chain that normally passes over the lift-wheel (sprocket) or idler sprocket on multi-reeved hoist. Examine the chain links for wear (see figure 15). If the wire diameter anywhere on the link measures less than 90% of the nominal wire diameter, the chain must be replaced.

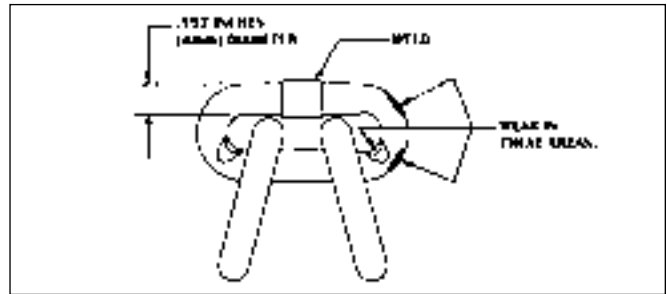

4. Based upon ASME B30.16, should also be checked for elongation. Select an unworn, unstretched length of the chain (at the slack end for example). Suspend the chain vertically under tension and using a knife blade caliper type gauge, measure the outside length of any convenient number of links, 11 is recommended. Measure the same number of links in the used sections and calculate the percentage in increased length. The chain should be replaced if the length of the used portion is more than 1.5% longer than the unused portion of the chain. Also, if the pitch of any individual link has elongated by more than 5%, the chain should be replaced.

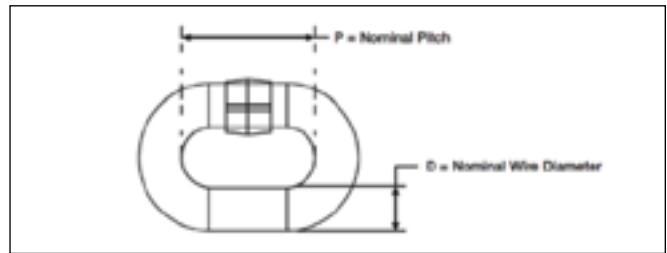

Figure 15. Chain Wear Areas

Models	P	D
B, C & F	.745" (18.9mm)	.250" (6.3mm)
J, L, LL, R & RR	.858" (21.8mm)	.312" (7.9mm)
RRS	1.18" (30.0mm)	.394 (10.0mm)

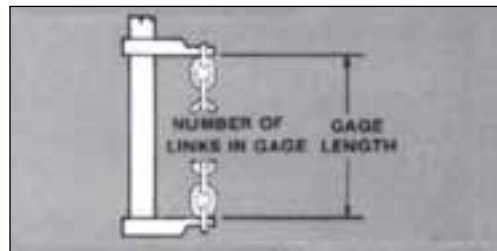

Figure 16. Gaging Load Chain Wear

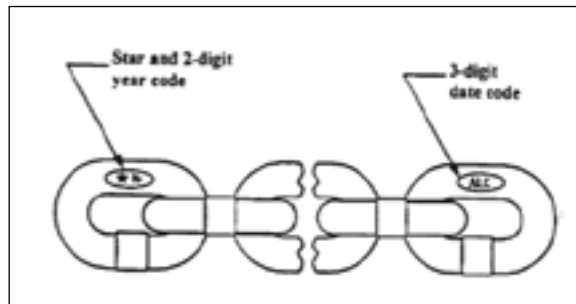

Figure 17. Chain Embossing

Use only Star (*) grade load chain and original replacement parts. Use of other chain and parts may be dangerous and voids factory warranty.

IMPORTANT: Do not use replaced chain for other purposes such as lifting or pulling. Load chain may break suddenly without visual deformation. For this reason, cut replaced chain into short lengths to prevent use after disposal.

⚠ WARNING
Use Of Commercial Or Other Manufacturer's chain and parts to repair CM hoists may cause load loss.
TO AVOID INJURY:
Use only CM supplied replacement load chain and parts. Chain and parts may look alike, but CM chain and parts are made of specific material or processed to achieve specific properties.

MAINTENANCE

LOAD-LIMITER

The Load-limiter should operate for the normal life of the hoist without service. The device has been calibrated at the factory for a specific model of hoist. For proper overload protection, be sure before installing a Load-limiter that it is correct for the unit. This is mechanical load protection only and contains no electrical sensing.

Models	Load-limiter Part Number	Load-limiter ID # (marked on Proteccor)
B	C00000240	240
C, F	C00000241	241
J, L, R	C00000242	242
LL, RR, RRS	C00000243	243

For appropriate D8+ Load-Limiter see parts blow-out.

HOIST LUBRICATION

⚠ WARNING
The lubricants used in and recommended for the Lodestar Hoist may contain hazardous materials that mandate specific handling and disposal procedures.
TO AVOID INJURY:
Handle and dispose of lubricants only as directed in applicable material safety data sheets and in accordance with applicable local, state and federal regulations.

GEARS

NOTE: To assure extra long life and top performance, be sure to lubricate the various parts of the Lodestar Hoist using the lubricants specified in lubrication section. If desired, these lubricants may be purchased from CM. Refer to spare parts section for information on ordering the lubricants.

The gearbox is packed at assembly with grease and should not need to be renewed unless the gears have been removed from the housing and degreased.

If the gears are removed from the housing, wipe the excess grease off with a soft cloth and degrease the gears and housings. Upon reassembly, add grease to gears and housing. FULLY COAT GEAR TEETH AND PACK GEAR BOX, Models B, C & F require 7 fl. oz. of grease. Models J, L, LL, R and RR require 15 fl. oz. of grease. For Model RRS hoist: A total of 22 fluid ounces of grease.

- The limit switch gears are of molded nylon and require no lubrication.
- Apply a light film of machine oil to the limit switch shaft threads at least once a year.

BEARINGS

- All bearings and bushings, except the lower hook thrust bearing, are pre-lubricated and require no lubrication. The lower hook thrust bearing should be lubricated at least once a month.

CHAIN GUIDES, LIFTWHEEL AND LOWER SHEAVE WHEEL

- When the hoist is disassembled for inspection and/or repair, the chain guides, lower sheave wheel (on double chain units) and liftwheel must be lubricated with Lubriplate Bar and Chain Oil 10-R (Fiske Bros. Refining Co. or equivalent) prior to reassembly. The lubricant must be applied in sufficient quantity to obtain natural runoff and full coverage of these parts.

LOAD CHAIN

A small amount of lubricant will greatly increase the life of load chain. **Do not allow the chain to run dry.**

Keep it clean and lubricate at regular intervals with Lubriplate Bar and Chain Oil 10-4 (Fiske Bros. Refining Co.) or equal lubricant. Normally, weekly lubrication and cleaning is satisfactory, but under hot and dirty conditions, it may be necessary to clean the chain at least once a day and lubricate it several times between cleanings.

When lubricating the chain, apply sufficient lubricant to obtain natural run-off and full coverage, especially in the interlink area.

⚠ WARNING
Used motor oils contain known carcinogenic materials.
TO AVOID INJURY:
Never use used motor oils as a chain lubricant. Only use Lubriplate Bar and Chain Oil 10-R as a lubricant for the load chain.

DC BRAKE ASSEMBLY The correct air gap between field and armature is .008-.018 in (0.2-0.45 mm) for models A through H and .008-.020 in (0.2-0.5 mm) for models J through RRT. The DC brake is not adjustable. As the friction material wears, the brake gap increases. If the maximum air gap is reached, a new friction disc/rotor should be installed.

LIMIT SWITCH ADJUSTMENT

If limit switch operation has been checked as described on page 10 and is not operating correctly or is not automatically stopping the hook at a desired position, proceed as follows:

1. Disconnect hoist from power supply.
2. Remove back frame cover, see Figure 13.
3. The identification of upper and lower limit switches are indicated on the fiber insulator.
4. Loosen the 2 screws or the spring back the rotatable guide to disengage the travel nut.

Table 6a. Limit Switches

Model	Hook Travel w/ 44 T.P.I. Shaft (Standard)		Hook Travel w/ 56 T.P.I. Shaft (Standard)		Hook Travel w/ 64 T.P.I. Shaft (Standard)	
	Max Length of Lift		Max Length of Lift		Max Length of Lift	
	m	ft	m	ft	m	ft
C	63	206	80	262	91	299
B, F	5	15	41	133	46	152
L, J	39	127	49	162	56	185
LL	76	250	97	318	111	363
R	20	64	25	81	28	93
RR	38	124	48	158	55	181
RRS	38	125	48	159	55	182

Table 6b. Limit Switches

Model	Hook Travel, per Notch		A (minimum distance between top of hook block and bottom of hoist)		B (minimum length of loose end chain)
	mm	in	mm	in	
C	52.8	2.08	38.1	1.50	6 links
B, F	26.9	1.06	38.1	1.50	6 links
L, J	30.5	1.20	38.1	1.50	8 links
LL	116.8	4.60	63.5	2.50	8 links
R	15.2	0.60	63.5	2.50	8 links
RR	29.7	1.17	63.5	2.50	8 links
RRS	30.0	1.18	63.5	2.50	30 links

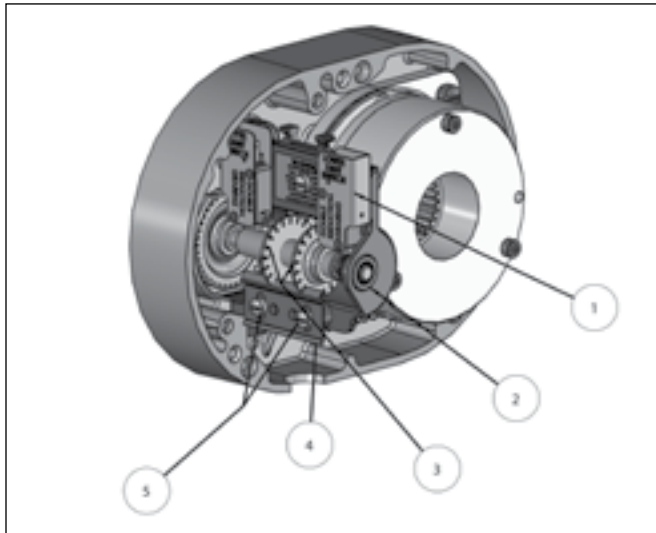

Figure 18. Limit Switches, Models B, C & F

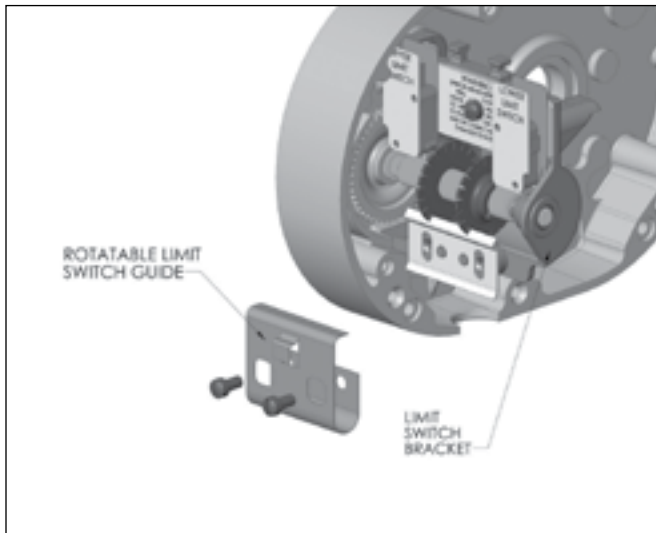

Figure 18A. Rotatable Limit Switches, Models B, C & F

1. Limit switch sub-assy
2. Limit switch shaft
3. Traveling nuts
4. Guide plate
5. Screws

SETTING UPPER LIMIT SWITCH

After completing steps 1 thru 4

5. Refer to table 6 -The "A" Dimensions given are the minimum distance that should be set between the top hook block and the bottom of the hoist.

CAUTION: THE "A" DIMENSIONS SHOWN IN TABLE 6 ARE THE MINIMUM ALLOWED FOR SAFE OPERATION AND SHOULD NOT BE REDUCED.

6. Reconnect hoist to power supply.
7. Run hook to the desired upper position,cautiously operating the hoist without a load.
8. Disconnect hoist from power supply.
9. Moving one travel nut toward the other increases hook travel and away from the other decreases the travel. Now, turn the nut nearest the switch indicated as the "UPPER LIMIT SWITCH" until it just breaks the limit switch contacts, cautious not to allow the movement of the other travel nut if previously set. An audible click will be heard as the switch opens. Continue to rotate the nut toward the switch an additional one full tooth.

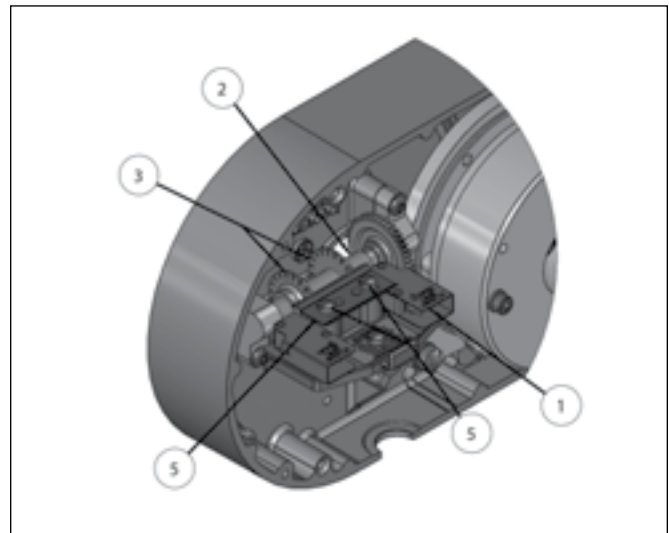

Figure 19. Limit Switches, Models J, L, LL, R, RR & RRS

1. Limit switch sub-assy
2. Limit switch shaft
3. Traveling nuts
4. Guide plate
5. Screws

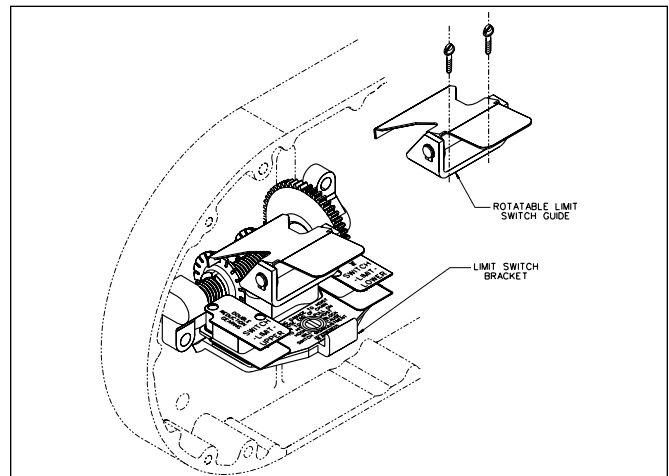

Figure 19A. Rotatable Limit Switches, Models J, L, LL, R, RR & RRS

10. Securely reposition the guide plate in the slot
11. Reconnect hoist to power supply and check the stopping point of hook by first lowering the hook about 2 feet (61 cm), then raise the hook by jogging cautiously until the upper limit switch stops upward motion. The stopping point of hook should be the desired upper position. If not, repeat the above instructions.
12. Double check setting by lowering the hook about 2 feet (61 cm) and then run the hook into the upper limit with (UP) control held depressed.
13. Fine adjustment of the upper limit setting may be obtained by inverting the stationary guide plate in Step 10. The offset on the plate gives adjustments equivalent to 1/2 notch, see Table 6 for the "Hook Travel Per Notch of Limit Switch Nut". When inverting the plate, it may be necessary to use the notch adjacent to the one used in the preliminary setting.

SETTING LOWER LIMIT SWITCH

After completing steps 1 thru 4

5. Refer to Table 6 -The "B" dimensions given are the minimum length of loose end chain left on the loose side of the lift wheel when the hook is positioned at the lowest allowable hook position.

CAUTION: THE "B" DIMENSIONS SHOWN IN TABLE 6 ARE THE MINIMUM ALLOWED FOR SAFE OPERATIONS AND SHOULD NOT BE REDUCED.

6. Reconnect hoist to power supply.
7. Run hook to the desired lower position, cautiously operating the hoist without a load.
8. Disconnect hoist from power supply.
9. Moving one travel nut toward the other increases hook travel and away from the other decreases hook travel. Now, turn the nut nearest the switch indicated as the "LOWER LIMIT SWITCH" until it just breaks the limit switch contacts, cautious not to allow the movement of the other travel nut if previously set. An audible click will be heard as the switch opens. Continue to rotate the nut toward the switch an additional one full tooth.
10. Securely reposition the guide plate in the slot.
11. Reconnect hoist to power supply and check the stopping point of hook by first raising the hook about 2 feet (61 cm) then lower the hook by jogging cautiously until the lower limit switch stops downward motion. The stopping point of the hook should be the desired lower position, if not repeat the above instructions.
12. Double check setting by raising the hook about 2 feet (61 cm) and then run the hook into the lower limit with (DOWN) control held depressed.
13. Fine adjustment of the lower limit setting may be obtained by inverting the stationary guide plate in Step 10. (Not available with the rotatable guide plate). The offset on the gives adjustments equivalent to 1/2 notch, see Table 6 for the "Hook Travel Per Notch of Limit Switch Nut". When inverting the plate, it may be necessary to use the notch adjacent to the one used in the preliminary setting.

CONVERTING LIMIT SWITCH GUIDES

1. Disconnect the hoist from the power supply system.
2. Refer to the exploded views and remove the back frame cover from the hoist.
3. Remove and discard the limit switch guide plate - retaining the 2 screws.
4. Refer to Figure 18A and 19A and assemble the limit switch guide plate to the limit switch bracket. Secure using the 2 screws.

CHAIN STOP INSTALLATION

Place polyurethane stop block over loose end of chain and slide past desired spot that the chain stop is to be located. Place one half of chain stop on chain. Then place other half on top of the first half of chain stop. (Note: be sure that the half circle cut out side of one stop block half is aligned with hex cut out side.) Place one (1) nut into hex cutout insert one (1) screw with one (1) lock washer through hole opposite nut and loosely tighten. Repeat for second connection. Tighten both screw connections to ensure that they do not come loose.

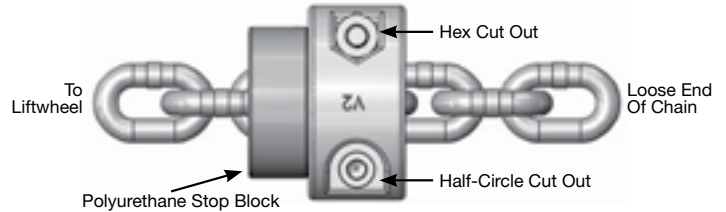

ELECTRICAL DATA

TO DETECT OPEN AND SHORT CIRCUITS IN ELECTRICAL COMPONENTS

Open circuits in the coils of electrical components may be detected by isolating the coil and checking for continuity with an ohmmeter or with the unit in series with a light or bell circuit.

Shorted turns are indicated by a current draw substantially above normal (connect ammeter in series with suspected element and impose normal voltage) or D.C. resistance substantially below normal. The current method is recommend for coils with very low D.C. resistance.

Motor current draw in the stator should be measured with the rotor in place and running. Brake, relay and contactor coil current should be measured with the core iron in operating position.

Table 7. Electrical Data For Hoist Components

Transformer Voltage	Leads	*D.C. Resistance (Ohms)
230/460 To 115	X1 To X2	24.6
	H1 To H2	106
	H3 To H4	130.
220/380 To 48	X1 To X2	4.0
	H1 To H2	106
	H3 To H4	130
.220/415 To 24	X1 To X2	1.1
	H1 To H2	106
	H3 To H4	130

Models	Contactor Coil Voltage	Nominal Current (Amps)	*D.C. Resistance (Ohms)
B thru RRS	115	0.04	29.75
	48	0.09	56.3
	24	0.19	14.9

*Resistance Values listed are nominal and they may vary slightly from component to component.

**On dual voltage units (230/460-3-60, 220/380-3-50 and 220/415-3-50), brake coils operate on 230 (220) volts.

Models	DC Brake Coil Voltage	Nominal Current (Amps)	*D.C. Resistance (Ohms)
B, C and F	103	0.243	424.4
	205	0.122	1681
	255	0.098	2601
J, L and R	103	0.311	331.5
J, L, LL, R RR, and RRS	205	0.161	1273
	255	0.118	2167

Models/ Cap.	Volts-Phase-Hertz	H.P. (kW)	Full Load Current (Amps)	Motor Leads	*D.C. Resistance (Ohms)		
B - 1/4 Ton (250 kg)	115/230-1-60	1/4 (.19)	4.6/2.3	1 to 2	4.3		
				3 to 4	4.3		
				5 to 8	4.9		
	110/220-1-50		1 to 2	7.2			
			3 to 4				
			5 to 8	5.8			
	230/460-3-60		1 to 4	14.8	1.4/7	1 to 2	29.5
			2 to 5				
	220/380-3-50		3 to 6		1.4/7	8 to 9	
			8 to 7				
220/415-3-50	8 to 7	1.4/7	9 to 7				
	9 to 7						
C - 1/4 Ton (250 kg) F - 1/2 Ton (500 kg)	115/230-1-60	1/2 (.37)	7.2/3.6		1 to 2	1.9	
					3 to 4		
					5 to 8		
	110/220-1-50		1 to 2		2.7	6.4/3.2	
			5 to 8				
			3 to 5	3.5			
	230/460-3-60		1 to 4	7.8	1.8/9	2 to 5	
			3 to 6				
	220/380-3-50		8 to 9		2.1/1.0	8 to 9	
			8 to 7				
	220/415-3-50		8 to 7		2.1/1.0	9 to 7	
			9 to 7				

Models/ Cap.	Volts-Phase-Hertz	H.P. (kW)	Full Load Current (Amps)	Motor Leads	*D.C. Resistance (Ohms)	
J - 1/2 Ton (500 kg) L - 1 Ton (1000 kg) R - 2 Ton (2000 kg)	115/1-60	1 (.74)	9.8	1 to 2	1.1	
				3 to 4		
	110/1-50		3 to 4	1.1		
			5 to 8		1.3	
J - 1/2 Ton (500 kg) L - 1 Ton (1000 kg) R - 2 Ton (2000 kg)	230/460-3-60	1 (.74)	3.0/1.5	1 to 4	4.7	
				2 to 5		
	220/380-3-50		3 to 6	9.4		
			8 to 9			
	220/415-3-50		8 to 7		3.6/1.8	9 to 7
			9 to 7			
LL - 1 Ton (1000kg) RR - 2 Ton (2000kg) RRS-2Ton (2000kg)	230/460-3-60	2 (1.5)	5.8/2.9		1 to 4	2.2
					2 to 5	
	220/380-3-50		3 to 6	9.4		
			8 to 9			
	220/380-3-50		8 to 7		6.4/3.3	9 to 7
			9 to 7			

TROUBLE SHOOTING ALL HOISTS TABLE 8

TROUBLE	PROBABLE CASE	REMEDY
1.) Hook does not respond to the control station or control device	A.) No voltage at hoist-main line or branch circuit switch open; branch line fuse blown or circuit breaker tripped.	A.) Close switch, replace fuse or reset breaker.
	B.) Phase failure (single phasing, three phase unit only)-open circuit, grounded or faulty connection in one line of supply system, hoist wiring, reversing contactor, motor leads or windings.	B.) Check for electrical continuity and repair or replace defective part.
	C.) Upper or lower limit switch has opened the control circuit.	C.) Press the “other” control and the hook should respond. Adjust limit switches as described on page 15.
	D.) Open control circuit-open or shorted winding in transformer, reversing contactor coil or loose connection or broken wire in circuit;mechanical binding in contactor control station contacts not closing or opening.	D.) Check electrical continuity and repair or replace defective part.
	E.) Wrong voltage or frequency.	E.) Use the voltage and frequency indicated on hoist identification plate. For three phase dual voltage unit, make sure the connections at the voltage change board are the proper voltage as described on page 8.
	F.) Low Voltage.	F.) Correct low voltage condition as described on page 8.
	G.) Brake not releasing-open or shorted coil winding; armature binding.	G.) Check electrical continuity and connections. Check that correct coil has been installed. The coil for three phase dual voltage unit operates at 230 volts when the hoist is connected for either 230 volt or 460 volt operation. Check brake adjustment as described on page 14.
	H.) Excessive load. Mechanical load protector slipping.	H.) Reduce loading to the capacity limit of hoist as indicated on the identification plate.
2.) Hook moves in wrong direction.	A.) Phase reversal (three phase unit only).	A.) Refer to installation instruction on page 8.
3.) Hook lowers but will not raise.	A.) Excessive load. Mechanical load protector slipping.	A.) See item 1H.
	B.) Open hoisting circuit-open or shorted winding in reversing contactor coil loose connection or broken wire in circuit; control station contacts not making; upper limit switch contacts open.	B.) Check electrical continuity and repair or replace defective part. Check operation of limit switch as described on page 18.
	C.) Phase failure (three phase unit only).	C.) See item 1B.
4.) Hook raises but will not lower	A.) Open lowering circuit-open or shorted winding in reversing contactor coil, loose connection or broken wire in circuit; control station contacts not making; lower limit switch contacts open.	A.) Check electrical continuity and repair or replace defective part. Check operation of limit switch as described on page 17.
5.) Hook lowers when hoisting control is operated.	A.) Phase failure (three phase unit only).	A.) See item 1B.
	B.) Phase reversal (three phase unit only).	B.) Refer to installation instruction on page 8.

TROUBLE SHOOTING ALL HOISTS TABLE 8

TROUBLE	PROBABLE CASE	REMEDY
6.) Hook does not stop promptly.	A.) Brake slipping.	A.) Check brake adjustment as described on page 14.
	B.) Excessive load.	B.) See item 1H.
7.) Hoist operates sluggishly.	A.) Excessive load.	A.) See item 1H.
	B.) Low voltage.	B.) Correct low voltage condition as described on page 9.
	C.) Phase failure or unbalanced current in the phases (three phase unit only).	C.) See item 1B.
	D.) Brake dragging.	D.) Check brake adjustment as described on page 14.
8.) Motor overheats.	A.) Low voltage.	A.) Correct low voltage condition as described on page 9.
	B.) Excessive load.	B.) See item 1H.
	C.) Extreme external heating.	C.) Above an ambient temperature of 40°C. (104°F), the frequency of hoist operation must be limited to avoid overheating of motor. Special provisions should be made to ventilate the space or shield the hoist from radiation.
	D.) Frequent starting or reversing.	D.) Avoid excessive inching, jogging or plugging. This type of operation drastically shortens the motor and contactor life and causes excessive brake wear.
	E.) Phase failure or unbalanced current in the phase (three phase unit only).	E.) See item 1B.
	F.) Brake dragging.	F.) Check brake adjustment as described on page 14.
9.) Hook fails to stop at either or both ends of travel.	A.) Limit switches not opening circuits.	A.) Check switch connections, electrical continuity and mechanical operation. Check the switch adjustment as described on page 15.
	B.) Limit Switch Shaft not rotating.	B.) Check for damaged Limit Switch gears.
	C.) Traveling nuts not moving along shaftguide plate loose; shaft or nut threads damaged.	C.) Tighten guide plate screws. Replace damaged part.
10.) Hook stopping point varies.	A.) Limit switch not holding adjustment.	A.) See item 9.
	B.) Brake not holding.	B.) Check the brake adjustment as described on page 14.
	C.) Binding of Limit Switch Shaft.	C.) Check Limit Switch Bearing for proper seating.

FIGURE 20A. TYPICAL WIRING DIAGRAMS

Wiring Diagrams shown are representative. Consult diagram in hoist or furnished with unit.

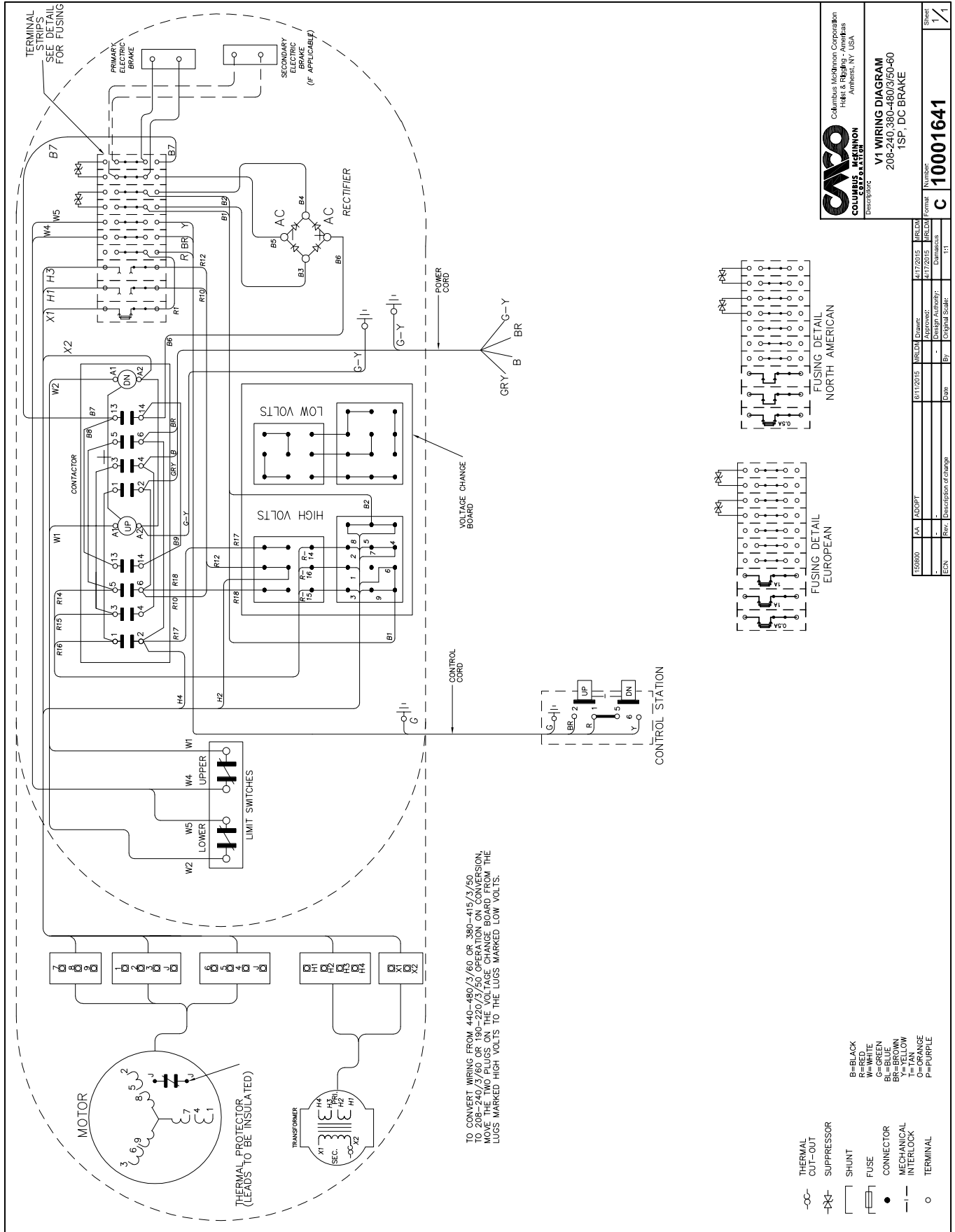

CALPICO
 COLUMBUS MCKIMM
 CONSULTANTS

Columbus McKimM Corporation
 Hoist & Elevator - Americas
 Amherst, NY, USA

V1 WIRING DIAGRAM
 208-240-380-480/3/50-60
 1SP, DC BRAKE

Number: **C 10001641**
 Form: **C**
 Sheet: **1/1**

ECN	Rev.	Description of Change	Date	By	Original Scale	Drawn	Checked	Appr.	MR/LDN	MR/LDN	MR/LDN
180800	AA	ADDPPT							4/17/2015	4/17/2015	4/17/2015



FIGURE 20B. TYPICAL WIRING DIAGRAMS

Wiring Diagrams shown are representative. Consult diagram in hoist or furnished with unit.

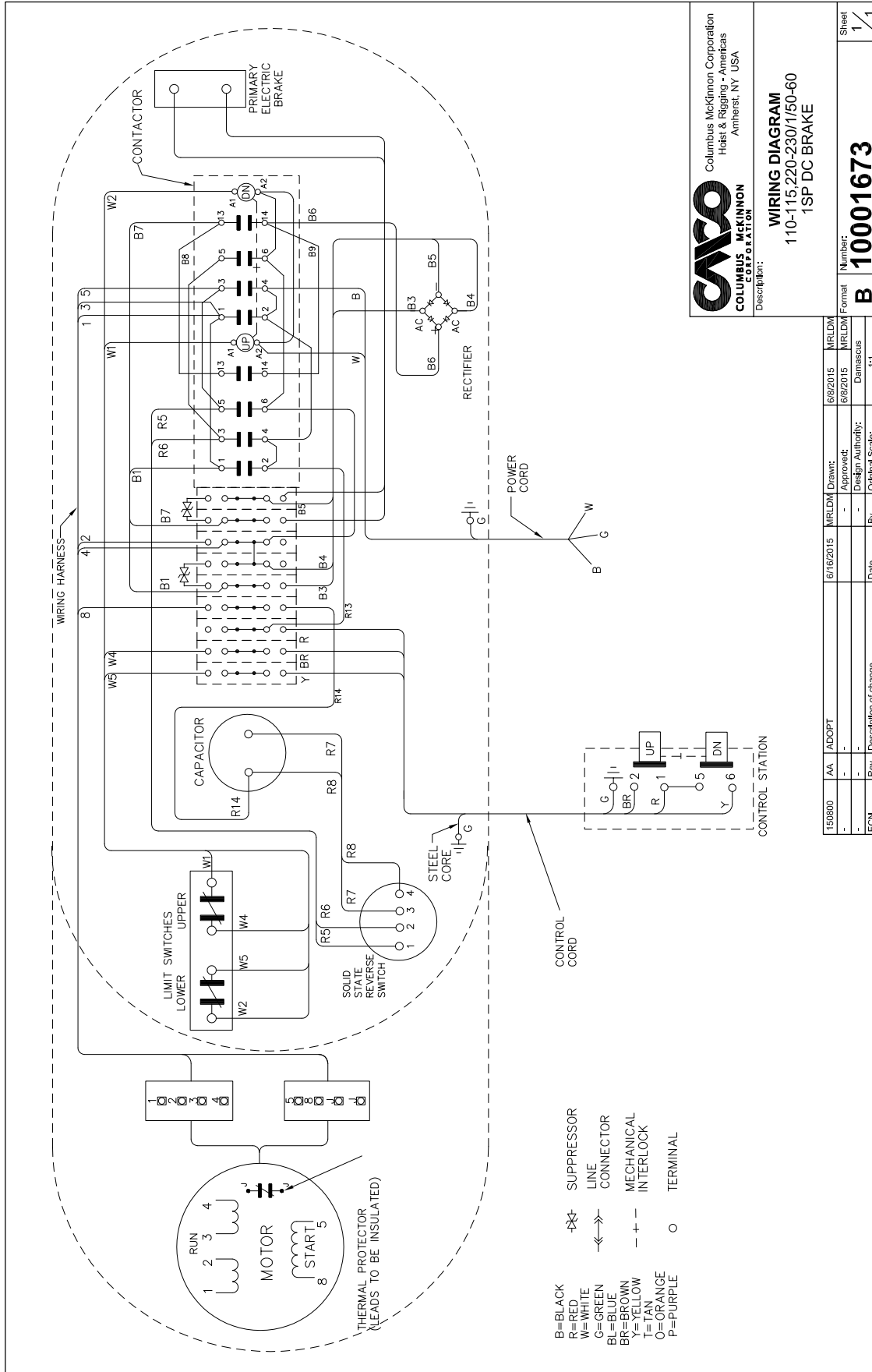

COLUMBUS MCKINNON CORPORATION
 Columbus McKinnon Corporation
 Hoist & Rigging - Americas
 Amherst, NY USA

WIRING DIAGRAM
 110-115,220-230/1/50-60
 1SP DC BRAKE

Number: **10001673**
 Format: **B**

ECN	Rev.	Description of change	Date	By	Original Scale:
150900	AA	ADOPT	6/16/2015		1:1
			6/6/2015		

MRLDM	Drawn:	6/6/2015	MRLDM
	Approved:		
	Design Authority:	Damasius	

Sheet	1
of	1

FIGURE 20C. TYPICAL WIRING DIAGRAMS

Wiring Diagrams shown are representative. Consult diagram in hoist or furnished with unit.

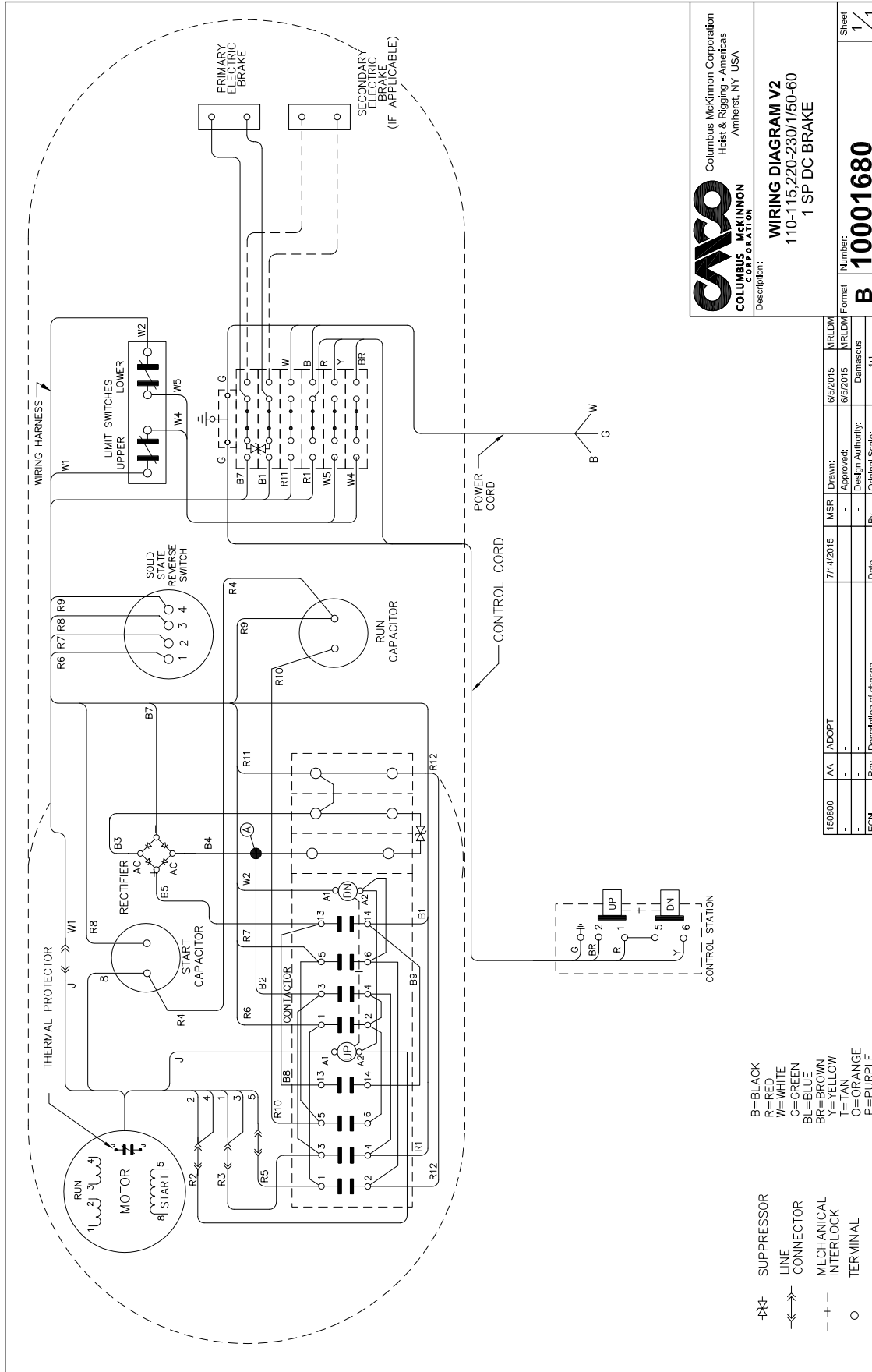

COLUMBUS MCKINNON CORPORATION
 Columbus McKinnon Corporation
 Hoist & Rigging - Americas
 Amherst, NY USA

WIRING DIAGRAM V2
 110-115,220-230/1/50-60
 1 SP DC BRAKE

Number: **10001680**
 Format: **B**
 Sheet: **1 / 1**

ECN	Rev.	Description of change	Date	By	Original Scale	Design Authority	Drawn	MSR	MRLDM
150900	AA	ADAPT	7/14/2015			Damasius	6/6/2015		6/6/2015
-	-	-	-	-	-	-	-	-	-
-	-	-	-	-	-	-	-	-	-

- X- SUPPRESSOR
 - - - LINE CONNECTOR
 - o MECHANICAL INTERLOCK
 - o TERMINAL
- B=BLACK
 - R=RED
 - W=WHITE
 - G=GREEN
 - BL=BLUE
 - BR=BROWN
 - Y=YELLOW
 - T=TAN
 - O=ORANGE
 - P=PURPLE



FIGURE 20D. TYPICAL WIRING DIAGRAMS

Wiring Diagrams shown are representative. Consult diagram in hoist or furnished with unit.

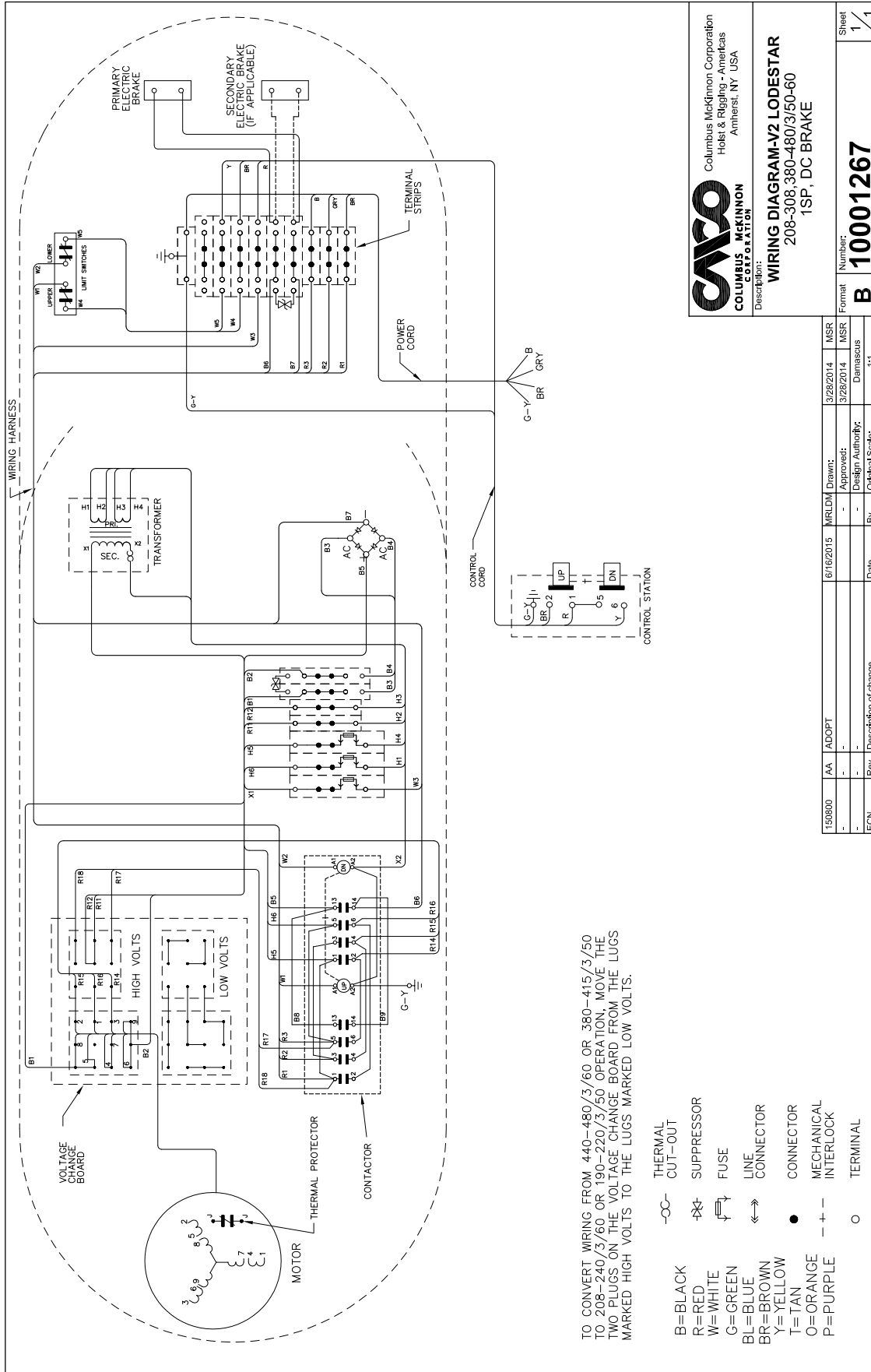

TO CONVERT WIRING FROM 440-480/3/60 OR 380-415/3/50 TO 208-240/3/60 OR 190-220/3/50 OPERATION, MOVE THE TWO PLUGS ON THE VOLTAGE CHANGE BOARD FROM THE LUGS MARKED HIGH VOLTS TO THE LUGS MARKED LOW VOLTS.

- B=BLACK
 - R=RED
 - W=WHITE
 - G=GREEN
 - BL=BLUE
 - BR=BROWN
 - Y=YELLOW
 - T=TAN
 - O=ORANGE
 - P=PURPLE
- OC- THERMAL CUT-OUT
 - X- SUPPRESSOR
 - f FUSE
 - ↔ LINE CONNECTOR
 - CONNECTOR
 - MECHANICAL INTERLOCK
 - TERMINAL

COLUMBUS MCKINNON CORPORATION
 Columbus McKinnon Corporation
 Hoist & Rigging - Americas
 Amherst, NY USA

WIRING DIAGRAM-V2 LODESTAR
 208-308,380-480/3/50-60
 1SP, DC BRAKE

Number: **10001267**

15980	AA	ADOPT	MRLDM	Drawn:	3/28/2014	MSR	Sheet	1
				Approved:	3/28/2014	MSR	1	1
				Design Authority:		Damasius		
				By				
				Date				
				Original Scale:		1:1		



FIGURE 20E. TYPICAL WIRING DIAGRAMS (DIRECT CONTROL)

Wiring Diagrams shown are representative. Consult diagram in hoist or furnished with unit.

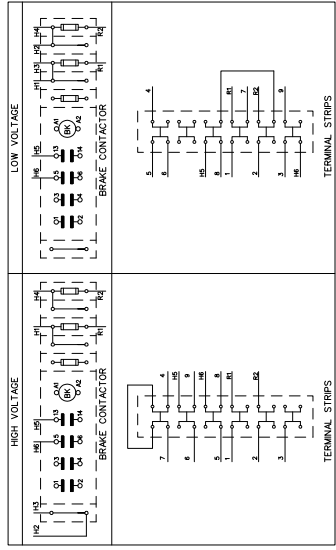
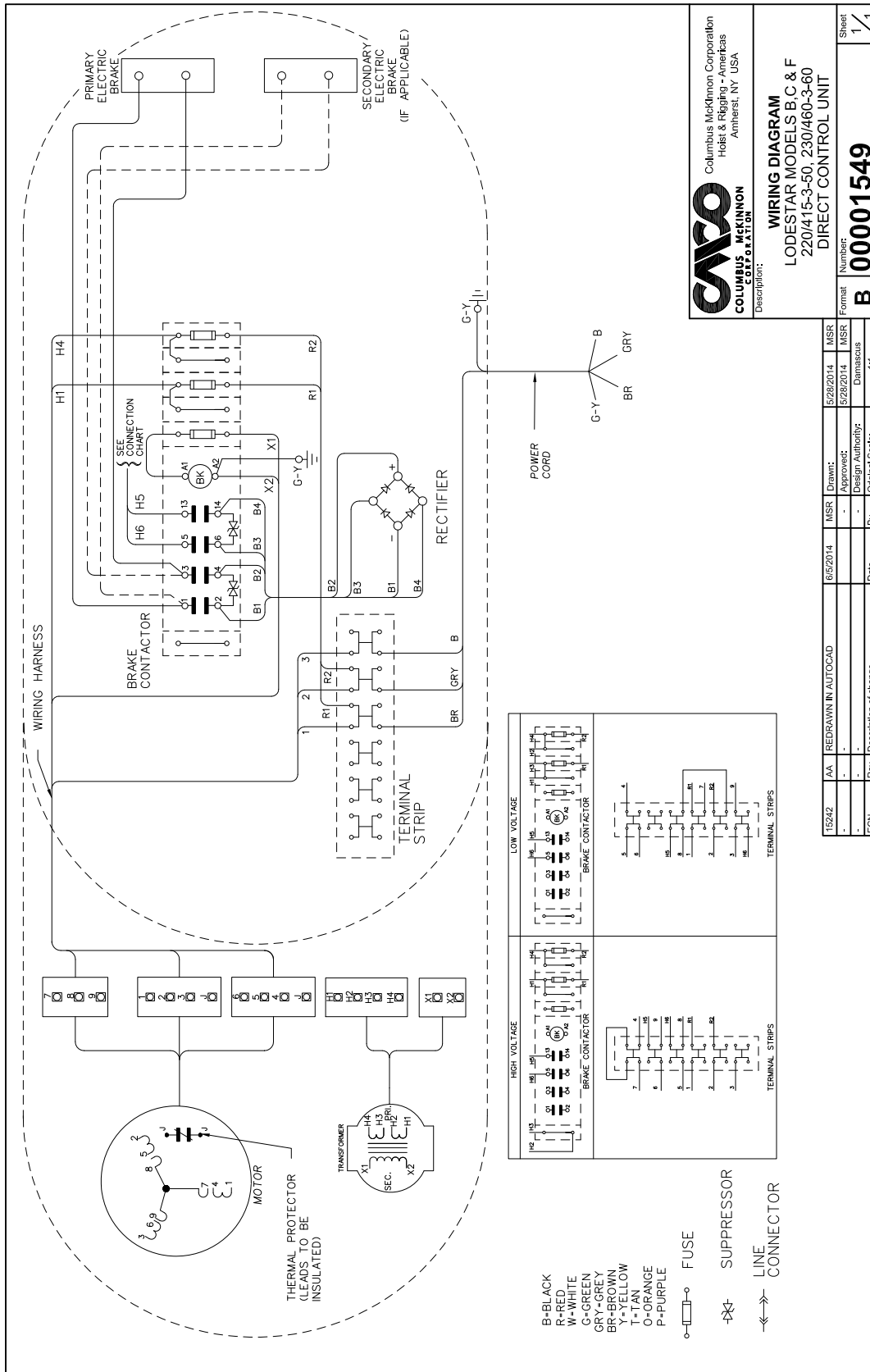

- B-BLACK
- R-RED
- W-WHITE
- C-GREEN
- GRV-GREY
- BR-BROWN
- Y-YELLOW
- T-TAN
- O-ORANGE
- P-PURPLE

- FUSE
- SUPPRESSOR
- LINE CONNECTOR

CMCO
COLUMBUS MCKINNON CORPORATION
Columbus McKinnon Corporation
Hoist & Rigging - Americas
Amherst, NY USA

WIRING DIAGRAM
LODESTAR MODELS B,C & F
220/415-3-50, 230/460-3-60
DIRECT CONTROL UNIT

Description: **B**
Number: **00001549**

MSR	6/5/2014	MSR	5/28/2014	MSR	5/28/2014
Drawn:		Approved:		Design Authority:	Damascus
Date		By		Original Scale:	1:1
ECN		Rev.		Description of change	

15242	AA	REDRAWN IN AUTOCAD	MSR	5/28/2014	MSR	5/28/2014	MSR	5/28/2014

FIGURE 20F. TYPICAL WIRING DIAGRAMS (DIRECT CONTROL)

Wiring Diagrams shown are representative. Consult diagram in hoist or furnished with unit.

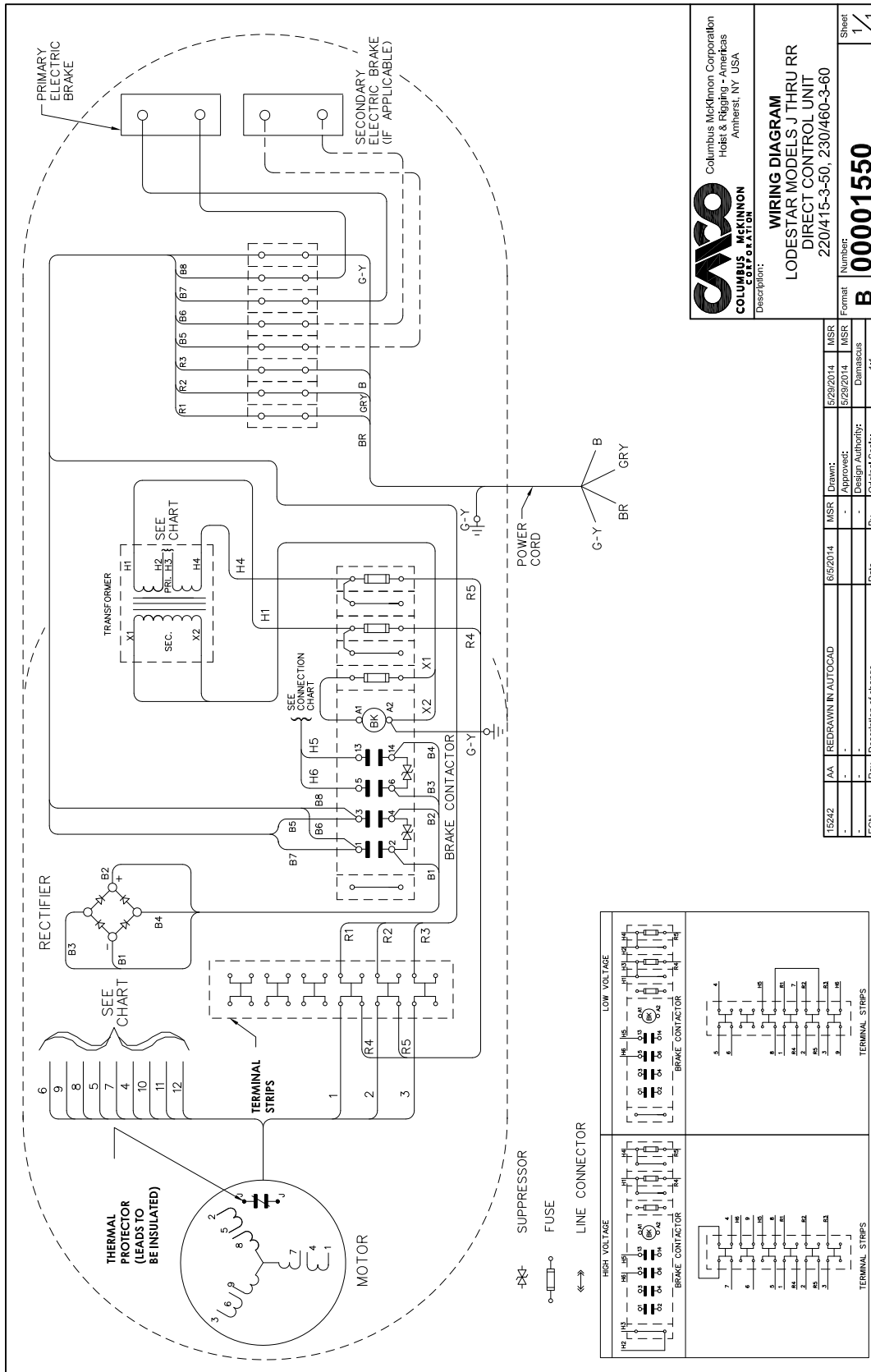

COLUMBUS MCKINNON CORPORATION
 Columbus McKinnon Corporation
 Hoist & Rigging - Americas
 Amherst, NY USA

WIRING DIAGRAM
 LODESTAR MODELS J THRU RR
 DIRECT CONTROL UNIT
 220/415-3-50, 230/460-3-60

Number: **00001550**

Format: **B**

Sheet: **1/1**

16242	AA	REDRAWN IN AUTOCAD	6/5/2014	MSR	Drawn:	5/29/2014	MSR
-	-	-	-	MSR	Approved:	5/29/2014	MSR
-	-	-	-	Damascus	Design Authority:	-	-
ECN	Rev.	Description of change	Date	By	Original Scale:	1:1	

ASSEMBLY INSTRUCTIONS

SWIVEL HOOK SUSPENSION

Models R & RR.

Assemble the dead end bolt and block through the suspension adapter as shown in Figure 21.



Figure 21. Swivel Hook Suspension

INSTRUCTIONS FOR ASSEMBLING UPPER SUSPENSION TO HOIST DOUBLE REEVED CHAIN MODELS

Place the suspension assembly into the recess provided on the hoist. The dead end block should project through the bottom of the hoist with the pin hole and slot aligned to the underside of the hoist as shown in the Figure 8 page 7. If these are not aligned as shown, lift the head of the bolt from the hex recess in the adapter and turn the bolt and block assembly and reseat the bolt head to obtain proper alignment. **DO NOT** change the position of the dead end block on the bolt to attain this alignment.

Check the position of the pin hole in the dead end block to make sure that it has not been disturbed from its factory settings. The distance from the top of the pin hole to the bottom of the hoist should not exceed 7/16" (11mm) for Models R & RR. If the distance is not correct, adjust the position of the dead end block to obtain the proper distance.

CAUTION: DO NOT apply oil or any other lubricant to the threads of the suspension adapter screws. Such lubricant will significantly affect the frictional characteristics and may damage the screw or nut if the screw is tightened to the recommended seating torques.

Now, insert the screws, supplied with the assembly, through the holes in the suspension adapter and thread these into the self-locking nut enclosed in the hoist. The screws will turn freely into the nut until the last 1/4" (6.35mm) of travel during which the resistance of the nut locking collar will be encountered. Securely tighten the screws to the recommended seating torque specified in Table 2, using a 12 point socket which fits the head of the screw.

WARNING

The suspension screws are special high strength screws and under no circumstances should screws other than these be used to attach the suspension to the hoist. If other than the supplied, high strength screws are used, they may break and allow the hoist to fall from the support and this may result in an accident that could cause injury and/or property damage.

SUSPENSION BOLT SHOULD BE REPLACED ANY TIME THE SUSPENSION IS REMOVED FROM THE HOIST

The dead end of the load chain is temporarily positioned (a few links from the end) by a wire clip. **DO NOT** remove this clip before attaching the chain to the dead end block. Refer to Figure 7, page 7 and the tag attached to the load chain on the hoist.

See Tables 2a and 2b for recommended torque values.

WARNING

USE OF IMPACT TOOLS (ELECTRIC OR PNEUMATIC) MAY CAUSE PREMATURE FAILURE OF ATTACHING HARDWARE.

Models B, C, F, J, L & LL

INSTRUCTIONS FOR ASSEMBLING UPPER HOOK SUSPENSION TO HOIST SINGLE CHAIN MODELS

Place the suspension assembly into the recess on the top of the hoist so that the adapter body follows the contour of the hoist.

CAUTION: DO NOT apply oil or any other lubricant to the threads of the suspension adapter screws. Such lubricant will significantly affect the frictional characteristics and may damage the screw or nut if the screw is tightened to the recommended seating torques. Insert the screws, supplied with this assembly, through the holes in the adapter and thread these into the self-locking nuts enclosed in the hoist. The screws will turn freely into the nuts until the last 1/4" (6.35mm) of travel during which the resistance of the nut locking collar will be encountered. Securely tighten the screws to the recommended seating torque specified in Table 2a or 2b, using a 12 point socket which fits the head of the screw.

For Model RRS: Remove the hook suspension, screw and locknut from the packaging. Slide the suspension assembly into the channel in the top of the hoist. Insert the locknut into the hex recess on the side of the suspension riser, insert the screw through opposite side and hand thread the screw into the self-locking nut. Securely tighten the screw to the recommended torque (see table 2), using a 3/16" hex bit socket.

FASTENERS

See tables 2a, b, c and d for recommended torque values.

LOWER HOOK BLOCK PIN

When removing or installing the lower hook pin, care must be taken so as to prevent damaging the pin and/or hook block. These pins are tapered groove pins and as a result, they can only be removed in one direction. To remove the pin, a V-Block, drift and hammer (or slow acting press) are required. The drift should be the same diameter as the pin (5/16" diameter (7.94mm) for Models B, C & F and 3/8" (9.52mm) diameter for Models J, L, LL, R & RR, and (7/16" diameter (11.11mm) for Model RRS1 and it should be placed on the small end of the pin. The small end of the pin is the end opposite the end on which the 3 grooves are visible. Place the hook block in the V-Block and drive the pin out using the drift and a hammer or slow acting press.

To re-install the pin, the parts must be arranged the same as they were when the pin was removed. To do this, use the small end of the pin as a gage. First check the holes in the hook block body and determine which hole is the largest. Place the hook body in the V-Block with the larger hole on top. Next, check each end of the hole in the lower hook chain block and determine which end is the largest. Place the chain in the slot of the chain block and insert the chain block, with the large hole on top, into the hook block body. Align the holes in the hook block body with the hole in the chain block and insert the small end of the pin in the hole. Push the pin in by hand until it stops and then use a hammer or slow acting press to drive the pin into position so that the end of the pin is flush with the outside surface of the hook block body.

WARNING

Use of improper lower hook chain block pin as well as improper installation of the pin can cause the pin to break and allow the load to fall.

TO AVOID INJURY AND PROPERTY DAMAGE:

Use only CM supplied, special high strength lower hook chain block pin to attach the chain to the lower hook block and install the pin as directed above.

REMOVAL AND INSTALLATION OF LOAD CHAIN

⚠ WARNING

Improper installation (reeving) of the load chain can result in a dropped load.

TO AVOID INJURY/DAMAGE:

- Verify use of proper size and type of hoist load chain for specific hoist.
- Install load chain properly as indicated below.

USE ONLY CM EN (formerly DIN) OR STAR (★) GRADE LOAD CHAIN AND CM REPLACEMENT PARTS. USE OF OTHER CHAIN AND PARTS MAY BE DANGEROUS AND VOIDS FACTORY WARRANTY.

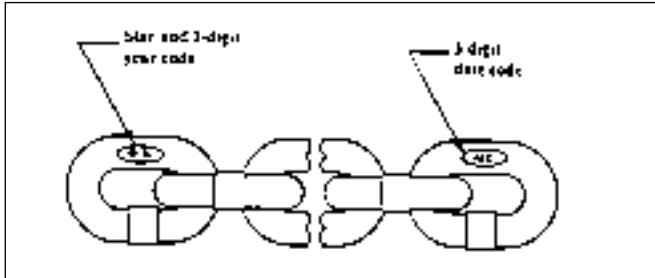

⚠ WARNING

USE OF COMMERCIAL OR OTHER MANUFACTURER'S CHAIN AND PARTS TO REPAIR CM HOISTS MAY CAUSE LOAD LOSS.

TO AVOID INJURY:

Use only CM supplied replacement load chain and parts. Chain and parts may look alike, but CM chain and parts are made of specific material or processed to achieve specific properties.

Hoist load chain can be installed by any one of several methods.

The first method is recommended when replacing severely worn load chain and requires disassembling the hoist. Method 2 does not require hoist disassembly, where as Method 3 requires only partial disassembly.

Method #1

- Disconnect hoist from power supply.
- Remove back frame cover and disengage the limit switch guide plate from the traveling nuts, see page 15 or 16.
- Detach loose end of load chain from hoist frame, see Figure 7. Also, on single reeved models, detach the lower hook block from the load chain (see page 45). On double reeved models R & RR unfasten the dead end side of load chain.
- Continue to disassemble the hoist and inspect the liftwheel, chain guides, motor housing and gear housing which if worn or damaged may cause premature failure of the new chain. Parts can be easily identified by referring to pages 31 thru 65.
- If the liftwheel pockets, in particular the ends, are worn or scored, replace liftwheel. If chain guides and housing are worn, cracked or damaged these parts should also be replaced.
- Reassemble hoist with the new load chain inserted over the liftwheel. Position chain with the weld on upstanding links away from liftwheel and leave only one foot of chain hanging free on loose end side. On double reeved models, make certain that the new load chain is free of twists.
- Attach the loose end link to chain and connect it to the hoist frame with the loose end screw, washer and lockwasher, see Figure 7. BE CERTAIN THERE IS NO TWIST.
- For single reeved models, attach the hook block to load chain

(see page 45) and proceed to step K.

- For double reeved models, run the hoist (UP) until only 914.4 mm (36" Inches) of chain remains on dead end side. This will minimize the chance of introducing a twist between hook block and hoist. Allow the chain to hang free to remove twists. j
- Using a wire as a starter, insert the chain, flat link first, into lower hook block (upstanding links will have weld toward sheave) and pull through. Insert last link into slot in dead end block making certain that no twist exists in the reeving at any point. Assemble dead end pin, washer and cotter pin as shown in Figure 7.
- Adjust limit switches as describe in Table 6, page 15. If the new chain is longer than the old, check to be sure limit switch will allow for new length of lift. In the event maximum adjustment does not allow entire length of lift, check with CM® for modification if necessary.

⚠ WARNING

Do not allow hook block to hit hoist or allow load chain to become taut between loose end screw and frame or else serious damage will result. If hook block should inadvertently hit the hoist-the hoist frames, load chain and hook block should be inspected for damage before further use.

Method #2

Treat the old load chain in hoist as a "starter chain" and proceed with steps from Method #1, a, b, c and h thru k. If a starter chain is used, the loose end link (two links required for double reeved models) can serve as a temporary coupling link to connect together the starter chain in the hoist and the new load chain to be installed. Then, under power, reeve the new load chain through the liftwheel area, replacing the starter chain in unit. Run enough chain through to attach loose end link to hoist frame.

CAUTION: For double reeved models, be sure to disconnect one of the loose end links from the load chain before attaching it to the hoist.

Method #3

- First proceed with Steps 1a, b & c from Method #1.
- Then, carefully run the load chain out of the hoist.
- Disconnect hoist from power supply.
- Remove the electric brake assembly.
- Rotate the brake hub by hand, at the same time feeding the load chain into and through liftwheel area with hoist upside down or using a wire to pull the load chain up onto the liftwheel as explained in Method #1 step 1f.
- Refer to Method #1 steps g thru j above to complete the installation.

CUTTING CHAIN

CM® Load chain is hardened and it is difficult to cut. The following methods are recommended when cutting a length of new chain from stock or cutting off worn chain.

1. Use a grinder and nick the link on both sides (Figure 23), then secure the link in a vise and break off with a hammer.
2. Use a 177.8 mm (7 inches) minimum diameter by 3.175 mm (1/8 inch) thick abrasive wheel (or type recommended by wheel supplier) that will clear adjacent links.
3. Use a bolt cutter (Figure 22) similar to the H.K. Porter No. 0590MTC with special cutter jaws for cutting hardened chain (25.4mm-1 inch) long cutting edge.

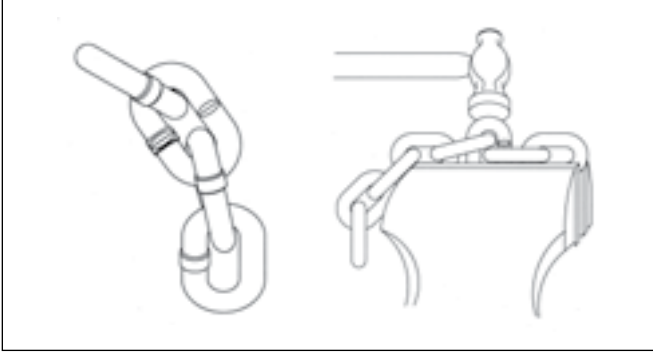

Figure 23. Cutting Chain by Nicking

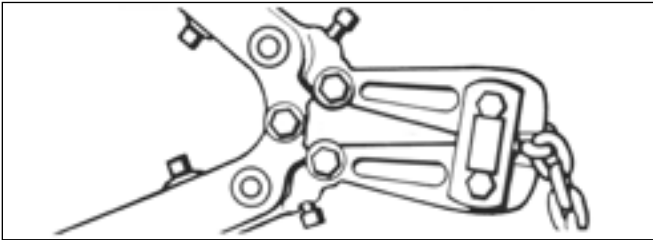

Figure 24. Cutting Chain with a Bolt Cutter

WARNING

Cutting Chain Can Produce Flying Particles.

TO AVOID INJURY:

- Wear Eye Protection.
- Provide A shield Over Chain to Prevent Flying Particles.

For Chain Stop Installation instructions, see page 16.

WARNING

TESTING OF MECHANICAL OVERLOAD PROTECTION

Before using, all altered, repaired or used hoists that have not been operated for the previous 12 months shall be tested by the user for proper operation. First test the unit without a load and then with a light load of 22.7 kg. (50 lb.) times the number of load supporting parts of load chain to be sure that the hoist operates properly and that the brake holds the load when the control is released. Next test with a load of *125% of rated capacity. In addition, hoists in which load sustaining parts have been replaced should be tested with *125% of rated capacity by or under the direction of an appointed person and written report prepared for record purposes. After this test, check that the Load-limiter functions.

*If Load-limiter prevents lifting of a load of 125% of rated capacity, reduce load to rated capacity and continue test.

NOTE: For additional information on inspection and testing, refer to Code B30.16 "Overhead Hoists" obtainable from ASME Order Department, 22 Law Drive, Box 2300, Fairfield, NJ 07007-2300, U.S.A

REPAIR PARTS LIST

WARNING

Using "Commercial" or other manufacturer's parts to repair the CM Lodestar Hoists may cause load loss.

TO AVOID INJURY:

Use only CM supplied replacement parts. Parts may look alike but CM parts are made of specific materials or processed to achieve specific properties



ORDERING INSTRUCTIONS

The following information must accompany all correspondence orders for replacement parts:

1. Hoist Model Number from identification plate.
2. Serial number of the hoist stamped below identification plate.
3. Voltage, phase, hertz from the identification plate.
4. Length of lift.
5. Part number of part from parts list.
6. Number of parts required.
7. Part name from parts list.

NOTE: When ordering replacement parts, it is recommended that consideration be given to the need for also ordering such items as gaskets, fasteners, insulators, etc. These items may be damaged or lost during disassembly or just unfit for future use because of deterioration from age or service.

V1-SMALL FRAME MODELS B, C, & F

V1-SMALL FRAME
MODELS B, C, & F

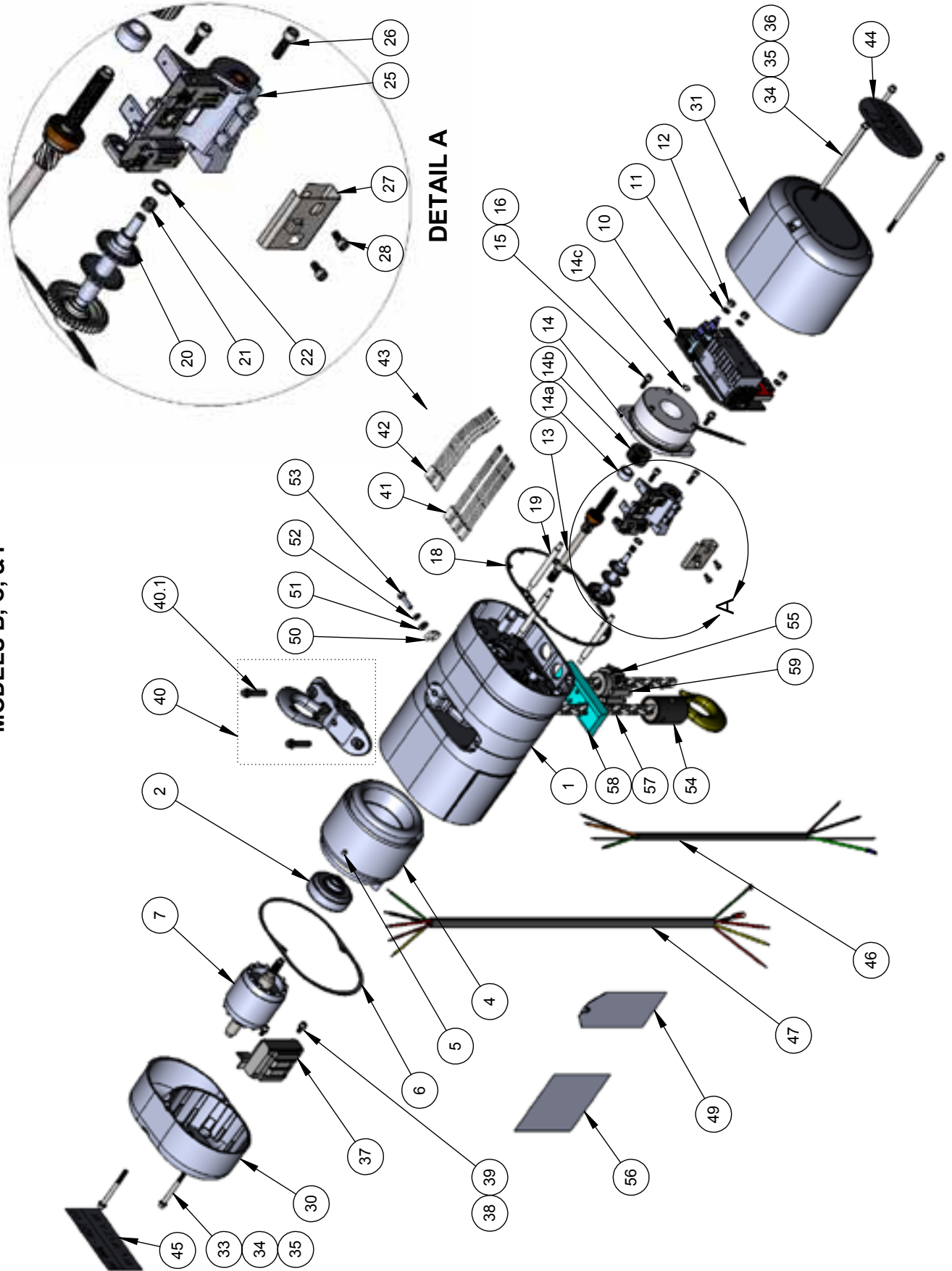

V1-SMALL FRAME MODELS B, C, & F

Item No.	Description	Model B	Model C	Model F	QTY.
1	GEAR BOX SUB-ASSY - DC BRAKE TYPE - SEE Gearbox Section	10001314B	10001313B	10001314B	1
2	CLUTCH ASSEMBLY	C00000240	C00000241	C00000240	1
3	D8+ CLUTCH ASSEMBLY	-		C00000240	**
4	STATOR - 115/230V-50HZ-1Ø	00000473	00000472	00000472	1
	STATOR - 115/230V-60HZ-1Ø	00000467	00000462	00000462	
	STATOR - 230/460V-3Ø	00000466	00000461	00000461	
5	STATOR PIN	983541			1
6	MOTOR COVER GASKET	27847			1
7	ROTOR ASSEMBLY 50HZ-1Ø	00000266	00000261	00000261	1
	ROTOR ASSEMBLY 60HZ-1Ø	00000265	00000261	00000261	
	ROTOR ASSEMBLY 3Ø	00000264	00000260	00000260	
8	EMPTY	-			-
9	EMPTY	-			-
10	CONTACTOR PLATE ASSEMBLY	SEE CONTACTOR PLATE SECTION			1
11	LOCKWASHER	982226			3
12	CONTACTOR PLATE MOUNTING NUT	982514			3
13	DRIVE SHAFT ASS'Y	10001348			1
14	BRAKE ASSEMBLY	SEE BRAKE SECTION			1
14a	BRAKE HUB SPACER	SEE BRAKE SECTION			0-1
14b	BRAKE HUB	SEE BRAKE SECTION			0-2
14c	BRAKE HUB SNAP RING	SEE BRAKE SECTION			1
15	LOCKWASHER	982226			2
16	BRAKE MOUNTING SCREW	982708			2
17	EMPTY	-			-
18	BACK FRAME COVER GASKET	10001344			1
19	CONTACTOR PLATE MOUNTING STUD	27836			3
20	LIMIT SWITCH SHAFT S/A	00000521			1
21	LIMIT SWITCH SHAFT SPRING	28712			1
22	WASHER	987878			1
23	EMPTY	-			-
24	EMPTY	-			-
25	LIMIT SWITCH BRACKET S/A	00000520			1
26	LIMIT SWITCH BRACKET SCREWS	10001265			2
27	LIMIT SWITCH SPRING GUIDE	52737			1
28	LIMIT SWITCH GUIDE MOUNTING SCREW	10001266			2
29	EMPTY	-			-
30	MOTOR COVER	27059			1
31	BACK FRAME COVER	10001341B			1
32	EMPTY	-			-
33	MOTOR COVER SCREW	987397			2
34	WASHER	982251			5
35	SCREW RETAINER	00001747			5
36	BACK FRAME COVER SCREW	87325			3
37	TRANSFORMER 24V SECONDARY	00000586			1*
	TRANSFORMER 48V SECONDARY	00000587			
	TRANSFORMER 120V SECONDARY	00000588			
38	LOCKWASHER	982226			2*
39	TRANSFORMER MOUNTING SCREW	1001695			2*
40	UPPER SUSPENSION ASSEMBLY	See Brake Section			1
40.1	SUSPENSION BOLT	987554			2
41	HARNNESS-SINGLE PHASE - DC BRAKE TYPE	00001543			1
	HARNNESS-THREE PHASE - DC BRAKE TYPE	00001540			
	HARNNESS-DIRECT CONTROL - DC BRAKE TYPE	00000573 & 00000332			
42	HARNNESS-V1 (3Ø ONLY)	00000749			1*
44	SERIES LABEL	00000780			1

Item No.	Description	Model B	Model C	Model F	QTY.
45	CAPACITY LABEL	00000772	00000772	00000773	1
	D8+ CAPACITY LABEL	-	-	00000213	**
46	POWER CORD-SINGLE PHASE	27759			1
	POWER CORD-THREE PHASE	23608608			
	POWER CORD-DIRECT CONTROL	23608608			
47	CONTROL CORD - SINGLE PHASE	29350 (INCLUDES ITEM 48)			1*
	CONTROL CORD - THREE PHASE	00000743			
48	WARNING TAG	81704			1
49	INSTRUCTION TAG	28275			
	INSTRUCTION TAG-DIRECT CONTROL	00000771			1
50	LOOSE END LINK	27351			1
51	WASHER	954802			1
52	LOCK WASHER	982226			1
53	LOOSE END SCREW	10001696			1
54	LOWER HOOK BLOCK ASSEMBLY	See hook block section			1
55	CHAIN STOP KIT	24015K			1
56	VOLTAGE LABEL	27698	27699	27696	1
57	LOAD CHAIN	85944 (ZINC PLATED)			AS REQ'D
		85973 (EN 818-7, ZINC PLATED)			
		85889 (BURNISHED AND OILED)			
		85965 (ZINC PHOSPHATE PLATED)			
		85915 (NICKEL PLATED)			
58	V2 EXTERNAL CHAIN PLATE	10001295			1
59	CHAIN PLATE CAPSCREW	10001296			2
60	RUBBER PLUG	27891			1**
61***	WARNING LABEL	00000779			1
62***	WARNING LABEL	36981			1
63***	RoHS LABEL	00000782			1
64***	LABEL, ELECTRICAL INFORMATION	24846			1
65***	CHAIN LABEL	928894			1
66***	WARNING LABEL, ELECTRICAL HAZARD	24842			2
67***	CE LABEL	40219			1
68***	CORD GRIPS	23251011			2***

*Not required for Direct Control units

**Only required for Direct Control units

***Not shown in exploded views

V2-LARGE FRAME MODELS J, L, LL, R, & RR

V2-LARGE FRAME MODELS J, L, LL, R, & RR

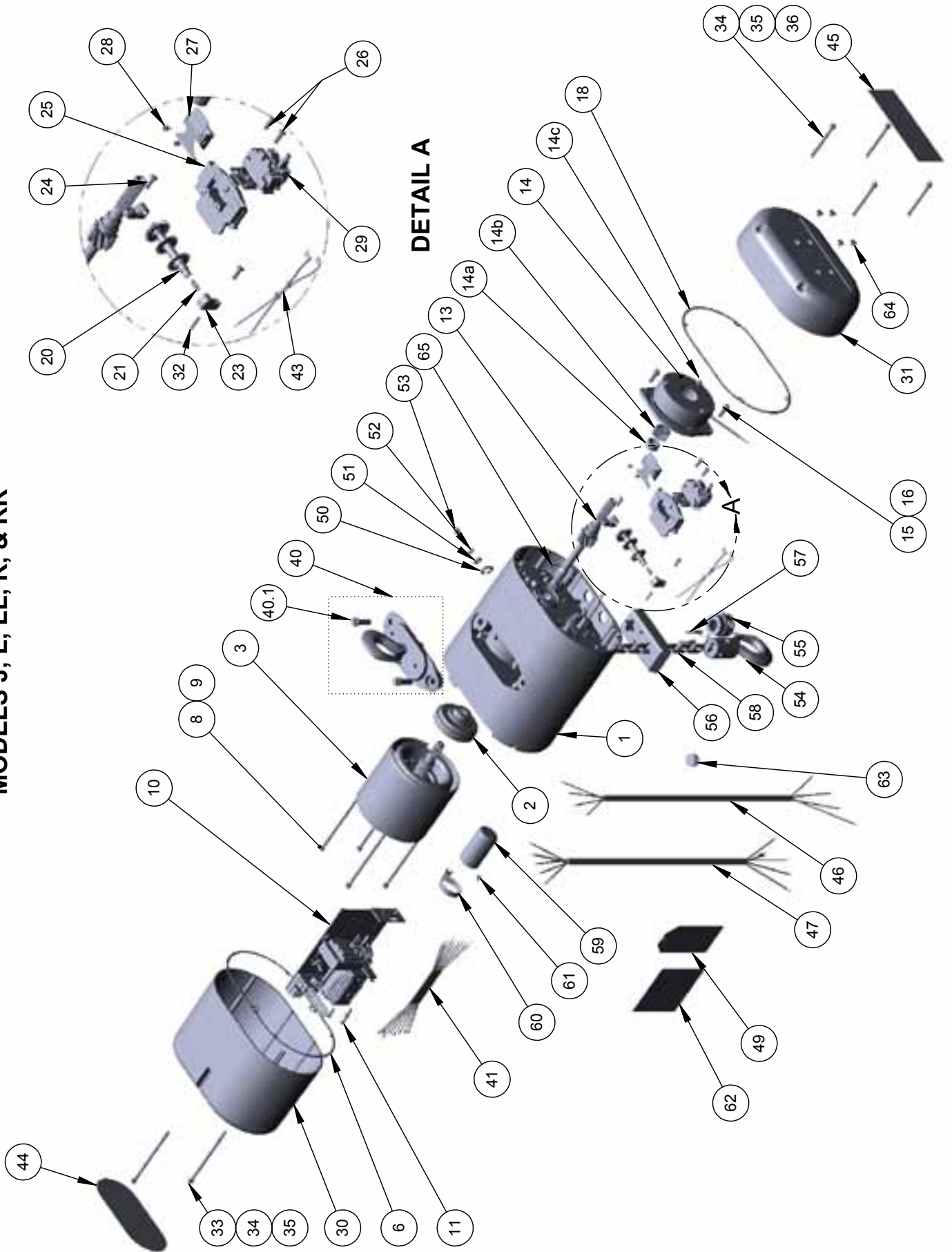

V2-LARGE FRAME MODELS J, L, LL, R, & RR

Item No.	Description	Model J	Model L	Model R	Model LL	Model RR	QTY.
1	GEAR BOX SUB-ASSY - DC BRAKE TYPE - SEE Page 60	10001315B	10001317B		10001315B		1
2	CLUTCH ASSEMBLY	C00000242			C00000243		1
	CLUTCH ASSEMBLY D8**+	C00000242	C00000288	C00000288	C00000242	C00000242	
3	3/4 MOTOR - 115V-1Ø	00000401			-		1
	3/4 MOTOR - 230/460V-3Ø	00000440			00000450		
	3/4 MOTOR - 230/460V-3Ø DIRECT CONTROL	00000402			00000408		
4	EMPTY	-			-		-
5	EMPTY	-			-		-
6	MOTOR COVER GASKET	35845					1
7	EMPTY	-			-		-
8	LOCKWASHER	982226					4
9	MOTOR MOUNTING SCREW	87377		87336			4
10	CONTACTOR PLATE ASSEMBLY	See Contactor Plate Section					1
11	CONTACTOR PLATE MOUNTING SCREW	983656					3
12	EMPTY	-			-		-
13	DRIVE SHAFT ASS'Y	10001351	10001350		10001351		-
14	BRAKE ASSEMBLY	See Brake Section					1
14a	BRAKE HUB SPACER	See Brake Section					0-2
14b	BRAKE HUB	See Brake Section					0-2
14c	BRAKE HUB SNAP RING	See Brake Section					1
15	LOCKWASHER	945851					2
16	BRAKE MOUNTING SCREW - DC BRAKE TYPE ONLY	10001697					2
17	EMPTY	-			-		-
18	BACK FRAME COVER GASKET	10001345					1
19	EMPTY	-			-		-
20	LIMIT SWITCH SHAFT S/A	00000525	00000524	00000524	00000525	00000525	1*
21	LIMIT SWITCH SHAFT SPRING	35703					1*
22	EMPTY	-			-		-
23	LIMIT SWITCH BEARING	35751					2*
24	LIMIT SWITCH BEARING SCREWS	983656					2*
25	LIMIT SWITCH BRACKET S/A	36827					1*
26	LIMIT SWITCH BRACKET SCREWS	983656					2*
27	LIMIT SWITCH GUIDE PLATE - ROTATABLE	52500					1*
28	LIMIT SWITCH GUIDE MOUNTING SCREW	983614					2*
29	TERMINAL STRIP S/A - FOR DC BRAKE	00000534					1*
	TERMINAL STRIP S/A - FOR AC BRAKE	00000380					
30	MOTOR COVER	36025B					1
31	BACK FRAME COVER	10001343B					1
32	BACKFRAME COVER PINS	983784					4
33	MOTOR COVER SCREW	10001654					2
34	WASHER	982251					6
35	SCREW RETAINER	00001747					6
36	BACK FRAME COVER SCREW	10001655					4
37-39	EMPTY	-			-		-
40	UPPER SUSPENSION ASSEMBLY	SEE Page 42					1
40.1	SUSPENSION BOLT	36849					2
41	HARNES-SINGLE PHASE - DC BRAKE TYPE	00001545					1
	HARNES-THREE PHASE - DC BRAKE TYPE	00001547					
	HARNES-DIRECT CONTROL - DC BRAKE TYPE	00000212					
44	SERIES LABEL	00000781					1
45	CAPACITY LABEL	00000774	00000775	00000776	00000775	00000776	1
	CAPACITY LABEL D8+	00000214	00000783	00000784	00000214	00000215	
46	POWER CORD-SINGLE PHASE	29043					1
	POWER CORD-THREE PHASE	00000742					
	POWER CORD-DIRECT CONTROL	00000742					

Item No.	Description	Model J	Model L	Model R	Model LL	Model RR	QTY.
47	CONTROL CORD-SINGLE PHASE	29350					1*
	CONTROL CORD-THREE PHASE	00000744					
48	WARNING TAG	81704					1
49	INSTRUCTION TAG	28275					1
	INSTRUCTION TAG-DIRECT CONTROL	00000771					
50	LOOSE END LINK	35367					1
51	WASHER	954807					1
52	LOCK WASHER	945851					1
53	LOOSE END SCREW	10001698					1
54	LOWER HOOK BLOCK ASSEMBLY	SEE Pages 45-46					1
55	CHAIN STOP KIT	24016K					1
56	V2 EXTERNAL CHAIN PLATE	10001295					1
57	CHAIN PLATE CAP SCREW	10001296					2
58	LOAD CHAIN	85949 (ZINC PLATED)					AS REQ'D
		85983 (EN 818-7, ZINC PLATED)					
		85979 (BURNISHED AND OILED)					
		85966 (ZINC PHOSPHATE PLATED)					
		85916 (NICKEL PLATED)					
59	SOLID STATE REVERSE SWITCH	35499					1***
60	SOLID STATE REVERSE SWITCH CLAMP	27275					1***
61	SOLID STATE REVERSE SWITCH SCREW	982873					1***
62	VOLTAGE LABEL	27690	27687	27691	27692	27693	1*
63	RUBBER PLUG	27891					1**
64	BACK FRAME HOLE PLUGS	00000574					4
65****	WARNING LABEL	00000209					1
66****	WARNING LABEL	00000211					1
67****	RoHS LABEL	00000782					1
68****	LABEL, ELECTRICAL INFORMATION	24846					1
69****	CHAIN LABEL	928894					1
70****	WARNING LABEL, ELECTRICAL HAZARD	24842					2
71****	CE LABEL	40219					1
72****	CORD GRIPS	23251011					2

* Not required for Direct Control units
** Only required for Direct Control units
*** Single phase only
**** Not shown in exploded views

MODEL RRS

MODEL RRS

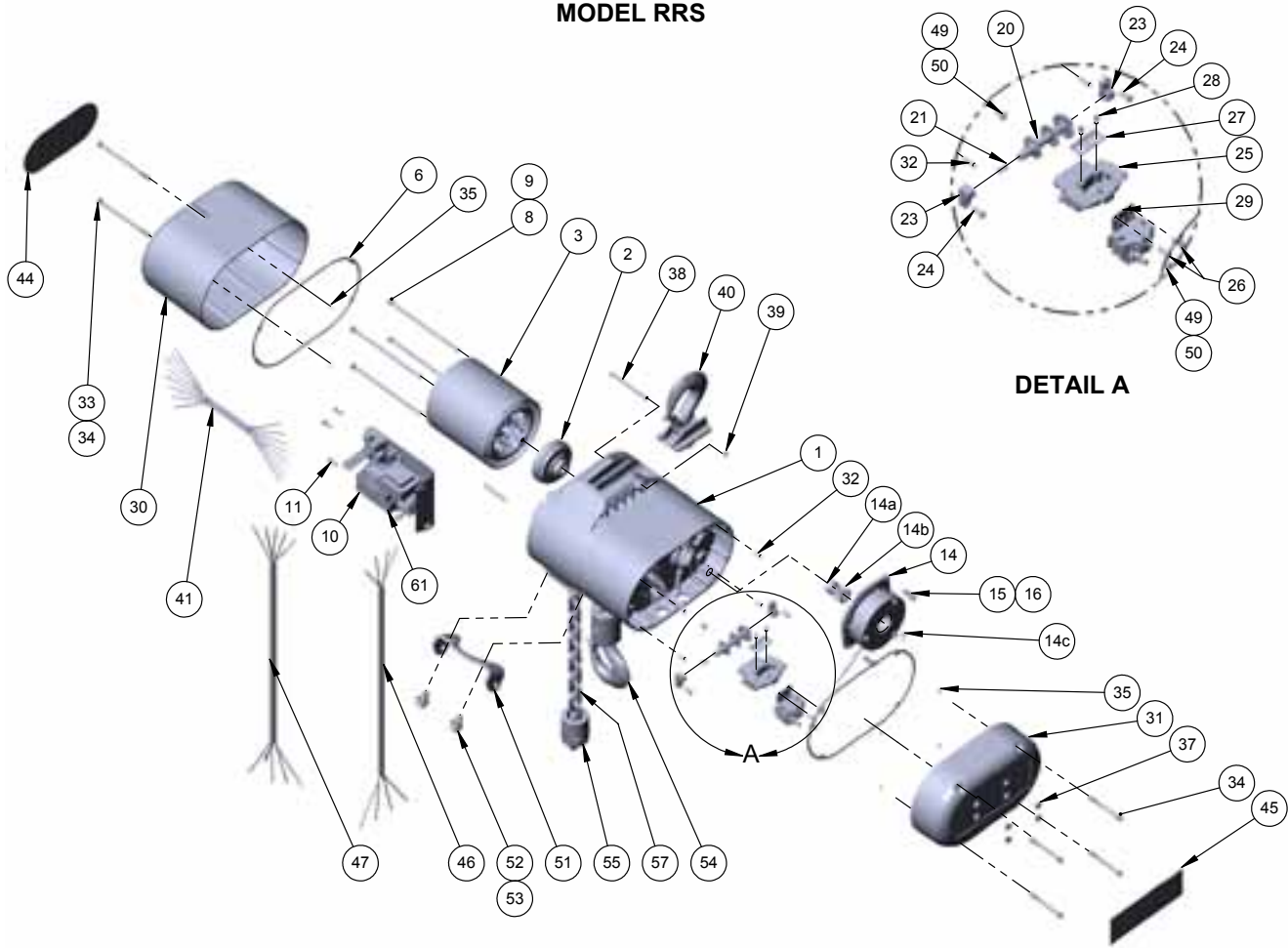

Item No.	Description	Part Number	STANDARD QTY.	D8+ QTY.	DIRECT CONTROL QTY.	D8+ DIRECT CONTROL QTY.
1	GEARBOX ASSEMBLY-BLACK	10001323B			1	
2	CLUTCH ASSEMBLY-V2-1 HP	C00000242	-	1	-	1
	CLUTCH ASSEMBLY-V2-2 HP	C00000243	1	-	1	-
3	MOTOR - 230/460V-WITH PLUG	10001023	1		-	
	MOTOR - 230/460V	10001040		-		1
4	-EMPTY-	-			-	
5	-EMPTY-	-			-	
6	GASKET-MOTOR COVER	10001019			1	
7	-EMPTY-	-			-	
8	LOCKWASHER	982226			4	
9	MOTOR MOUNTING SCREW	87334			4	
10	CONTACTOR PLATE ASSEMBLY	SEE PAGES XX-XX			1	
11	CONTACTOR PLATE MOUNTING SCREWS	983656			3	
12	-EMPTY-	-			-	
13	-EMPTY-	-			-	
14	BRAKE ASSEMBLY	SEE PAGES XX-XX			1	
14a	BRAKE HUB SPACER	00001433	1	2	1	2
14b	BRAKE HUB	00001431	1	2	1	2
14c	BRAKE HUB SNAP RING	10409711			1	
15	LOCKWASHER	945851			2	
16	BRAKE MOUNTING SCREW	10001697			2	
17	-EMPTY-	-			-	
18	BACKFRAME COVER GASKET	10001345			1	

Item No.	Description	Part Number	STANDARD QTY.	D8+ QTY.	DIRECT CONTROL QTY.	D8+ DIRECT CONTROL QTY.
19	-EMPTY-	-			-	
20	LIMIT SWITCH SHAFT S/A - 44 TPI	00000524		1		-
	LIMIT SWITCH SHAFT S/A - 56 TPI	00000526				
	LIMIT SWITCH SHAFT S/A - 64 TPI	00000528				
21	LIMIT SWITCH SHAFT SPRING	35703		1		-
22	-EMPTY-	-		-		-
23	LIMIT SWITCH BEARING	35751		2		-
24	LIMIT SWITCH BEARING SCREWS	983656		2		-
25	LIMIT SWITCH BRACKET S/A	36827		1		-
26	LIMIT SWITCH BRACKET SCREWS	983656		2		-
27	LIMIT SWITCH GUIDE PLATE	28714		1		-
	LIMIT SWITCH GUIDE - ROTATABLE (NOT SHOWN)	52500				
28	LIMIT SWITCH GUIDE PLATE MOUNTING SCREWS	10001266		2		-
29	TERMINAL STRIP S/A (230/460V-3Ø)	10001270		1		-
30	MOTOR COVER	36025B			1	
31	BACK FRAME COVER	10001343B			1	
32	BACK FRAME COVER PINS	983784			4	
33	MOTOR COVER SCREW	10001654			2	
34	WASHER	982251			6	
35	SCREW RETAINER	00001747			6	
36	BACK FRAME COVER SCREW	10001655			4	
37	HOLE PLUG	00000574			4	
38	SUSPENSION RETAINER SCREW	10001047			1	
39	SUSPENSION RETAINER NUT	82638			1	
40	UPPER SUSPENSION ASSEMBLY	SEE PAGES XX-XX			1	
41	WIRING HARNESS (230/460V-3Ø, CONTACTOR CTRL)	00001547		1		-
42	PUSH WIRE CONNECTOR (NOT SHOWN)	11782704		-	5	7
43	-EMPTY-	-			-	
44	SERIES LABEL	00000781			1	
45	CAPACITY LABEL-1000KG	00000215	-	1	-	1
	CAPACITY LABEL-2000KG	00000776	1	-	1	-
46	POWER CORD (DIRECT CONTROL)	00000740	-			1
	POWER CORD (CONTACTOR CONTROL)	00000742		1		-
47	CONTROL CORD	00000744		1		-
48	CONTROL CORD HOLE PLUG (NOT SHOWN)	27891		-		1
49	GROUND SCREW	987827			2	
50	LOCKWASHER	982226			2	
51	CHAIN CONTAINER BRACKET	10001041			1	
52	WASHER	10001043			2	
53	SCREW	982433			2	
54	LOWER HOOK ASSEMBLY	10001052			1	
55	CHAIN BLOCK KIT	10001029			1	
56	CHAIN STARTER LINK (NOT SHOWN)	85960LEL			1	
57	LOAD CHAIN, ZINC PLATED	85960EN			REQ'D LIFT + 3FT	
58	BEARING RETAINER SCREW (NOT SHOWN)	10565301		-	1	
59	BEARING RETAINER WASHER (NOT SHOWN)	987878		-	1	
60	BEARING RETAINER LOCKWASHER (NOT SHOWN)	982226		-	1	
61	FUSE CARTRIDGE*	10001405		2		-
62	FUSE 1A*	00000394		2		-
63	SHUNT**	29017		2		-

*Required for fuse protection of the transformer primary coil on contactor controlled hoists

**Shunts may be used in place of fuse & fuse cartridge, where allowable by applicable electrical codes

GEARBOX ASSEMBLY MODELS B, C, & F

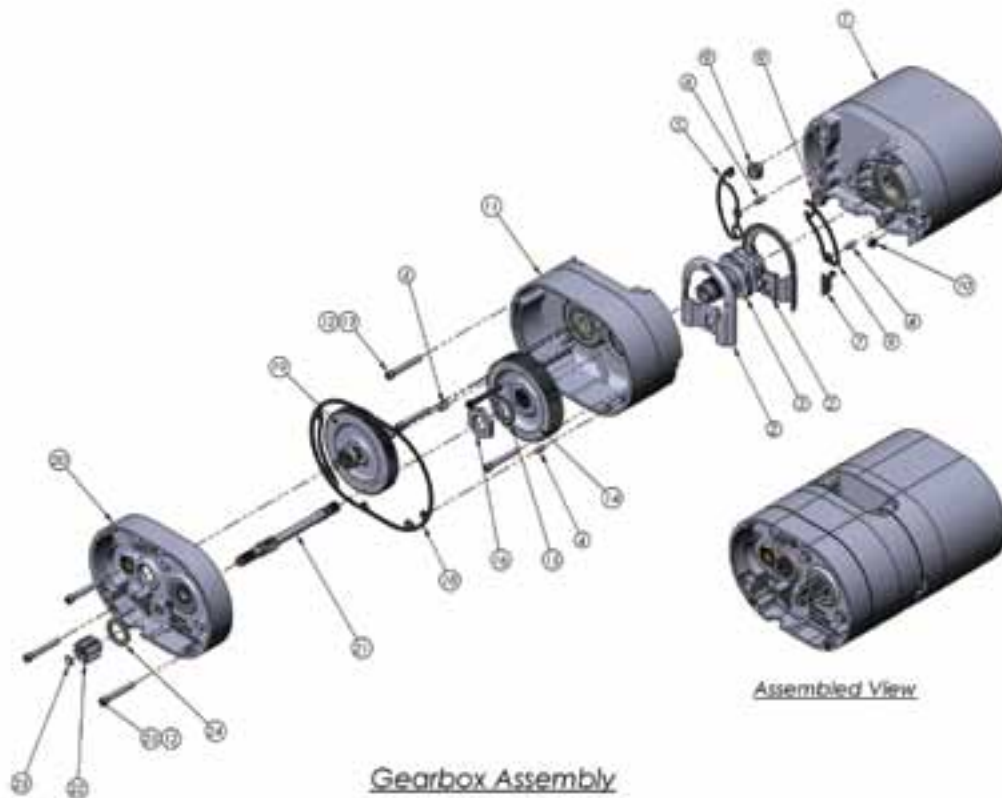

Item No.	Description	DC BRAKE TYPE			Qty.
		Model B	Model C	Model F	
1	GEARBOX SUB-ASSEMBLY	10001314B	10001313B	10001314B	1
1.1	MOTOR HOUSING SUB-ASSY	00000504B			1
1.2	CHAIN GUIDE	10001110			2
1.3	LIFT-WHEEL	10001591			1
1.4	O-RING - MOTOR END	10001388			1
1.5	O-RING - GEAR END	10001354			1
1.6	DOWEL PIN	82354			4
1.7	GASKET-MOTOR HOUSING WIREWAY	00000189			1
1.8	GASKET MOTOR HOUSING	00000190			1
1.9	GASKET MOTOR HOUSING	00000191			1
1.10	-EMPTY-	-			-
1.11	SUSPENSION NUT	927755			2
1.12	LOOSE END NUT	82638			1
1.13	GEAR HOUSING SUB-ASSY	00000502B			1
1.14	LOCKWASHER	940802			7
1.15	GEAR HOUSING SCREW	28830			4
1.16	LIFT-WHEEL GEAR	00000161 (59Teeth)	00000160 (45Teeth)	00000161 (59Teeth)	1
1.17	LOCK WASHER	00000199			1
1.18	LIFT-WHEEL NUT	00000198			1
1.19	-EMPTY-	-			-
1.20	GEAR HOUSING GASKET	10001346			1
1.21	INTERMEDIATE SHAFT SUB-ASSY	00000155 (88Teeth/8Teeth)	00000156 (88Teeth/12Teeth)	00000155 (88Teeth/8Teeth)	1
1.22	BACKFRAME SUB-ASSY	10001327B			1
1.23	BACKFRAME SCREW	982699			3

GEARBOX ASSEMBLY MODELS J, L, LL, R, & RR

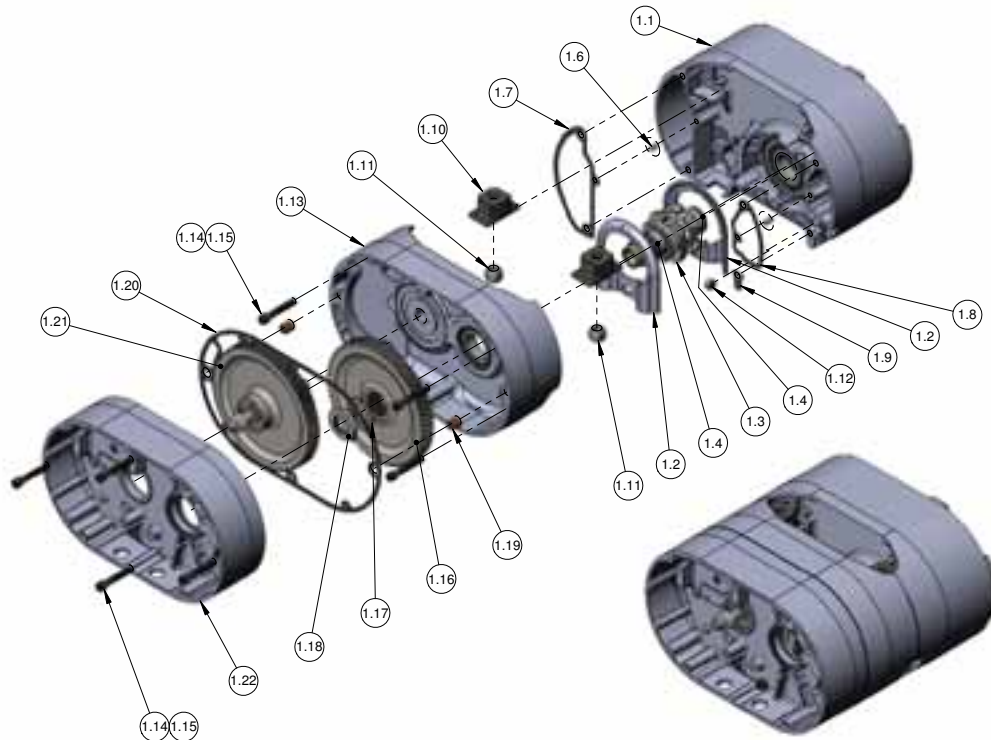

ASSEMBLED VIEW

Item No.	Description	Model J	Model L & RR	Model LL & RR	Qty.
1	GEARBOX SUB-ASSEMBLY	10001522B	10001317B	10001315B	1
1.1	MOTOR HOUSING SUB-ASSY		00000509B		1
1.2	CHAIN GUIDE		10001112		2
1.3	LIFT-WHEEL		10001592		1
1.4	O-RING		10001390		2
1.5	-EMPTY-		-		-
1.6	DOWEL PIN		82354		2
1.7	GASKET-MOTOR HOUSING WIREWAY		00000193		1
1.8	GASKET MOTOR HOUSING		00000194		1
1.9	GASKET MOTOR HOUSING		00000549		1
1.10	SUSPENSION ANCHOR		35066		2
1.11	SUSPENSION NUT		935791		2
1.12	LOOSE END NUT		82639		1
1.13	GEAR HOUSING SUB-ASSY		00000507B		1
1.14	LOCKWASHER		940830		8
1.15	GEAR HOUSING SCREW / BACKFRAME SCREW		982682		8
1.16	LIFT-WHEEL GEAR		00000163 (66 Teeth)		1
1.17	LOCK WASHER		986276		1
1.18	LIFT-WHEEL NUT		35773		1
1.19	ALIGNMENT BUSHING		35768		2
1.20	GEAR HOUSING GASKET		00000192		1
1.21	INTERMEDIATE SHAFT SUB-ASSY	10001636 (47 Teeth/8 Teeth)	00000171 (92 Teeth/8Teeth)	00000146 (47 Teeth/8 Teeth)	1
1.22	BACKFRAME SUB-ASSY		10001352B		1

MODEL RRS GEARBOX

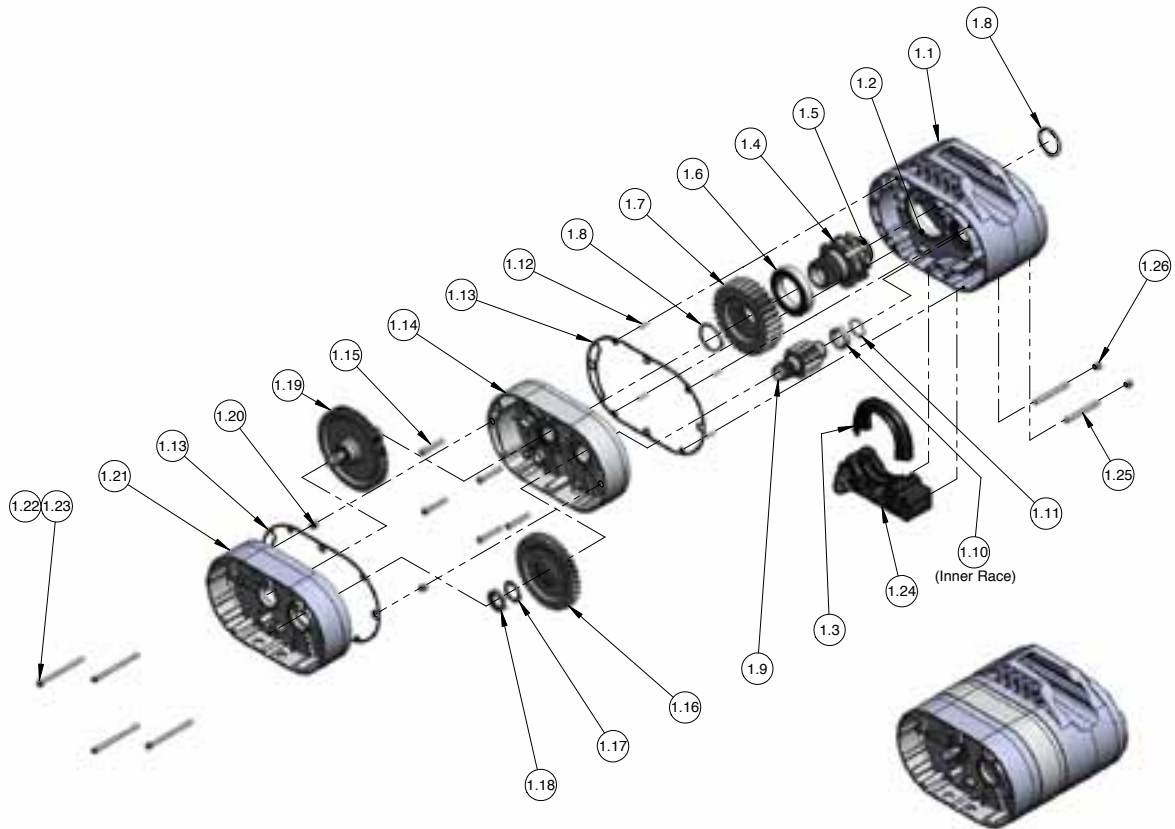

ASSEMBLED VIEW

Item No.	Description	Part Number	Qty.
1	GEARBOX ASSEMBLY	10001323B	1
1.1	MAIN FRAME SUB ASSEMBLY-BLACK	10001589B	1
1.2	O-RING - MAINFRAME	10001394	1
1.3	CHAIN GUIDE	10001004	1
1.4	LIFTWHEEL-5PKT-10MM X 30MM	10001588	1
1.5	O-RING - LIFTWHEEL	10001391	1
1.6	RADIAL BALL BEARING	10001017	1
1.7	GEAR-33T	10001006	1
1.8	RETAINING RING-EXTERNAL	10001108	2
1.9	PINION SUB-ASSY-12T	10001007	1
1.10	CYLINDRICAL ROLLER BEARING	10001016	1
1.11	RETAINING RING-EXTERNAL	10001107	1
1.12	SPRING PIN	983784	4
1.13	GASKET-GEAR HOUSING-V2	00000192	2
1.14	INT. FRAME-SUB-ASSY-BLACK	10001009B	1
1.15	SCREW	982682	5
1.16	GEAR - 42 TEETH	00000162	1
1.17	WASHER-LOCK-EXT TOOTH	986276	1
1.18	NUT	35773	1
1.19	SHAFT SUB-ASSY 10T/92T	10001011	1
1.20	DOWEL, BACK FRAME	35768	2
1.21	V2 BACKFRAME S/A-BLACK	10001352B	1
1.22	SCREW	80409	4
1.23	LOCKWASHER	940830	4
1.24	CHAIN CHUTE-MACHINED-BLACK	10001014B	1
1.25	DOWEL PIN	10001038	2
1.26	SET SCREW	10001045	2

UPPER SUSPENSIONS SMALL & LARGE FRAME

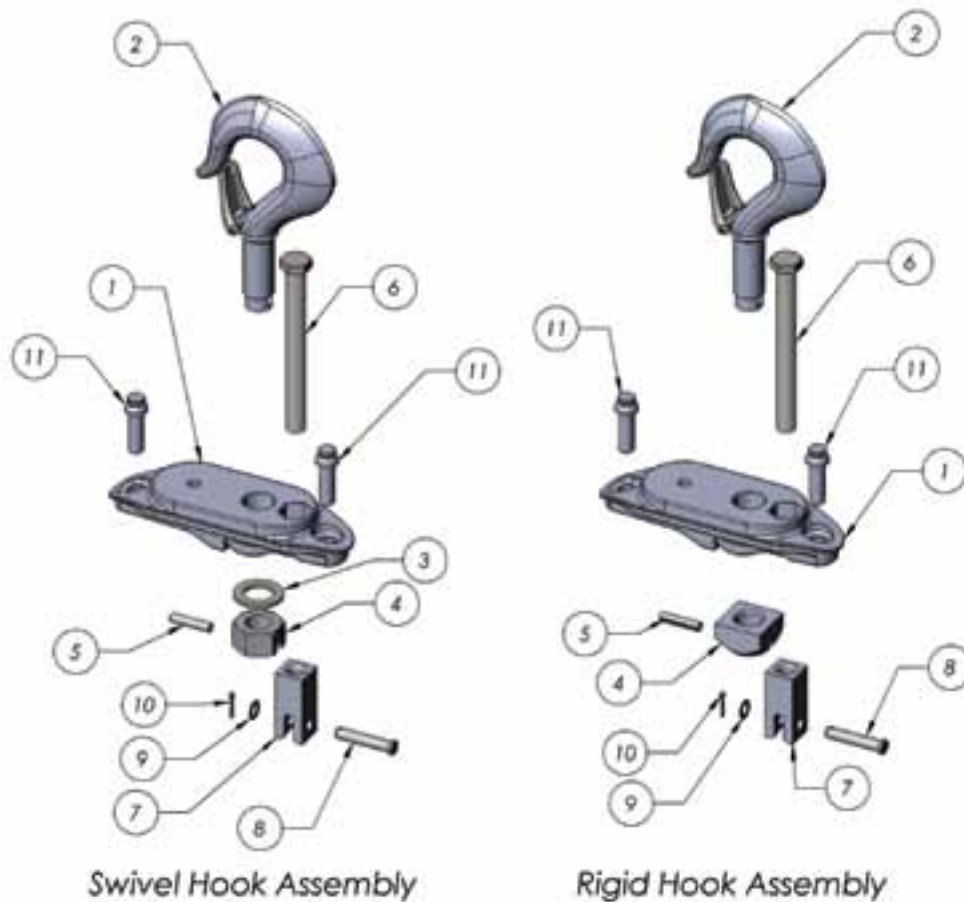

Item No.	Description	V1-SMALL FRAME PART NUMBERS	V2-LARGE FRAME PART NUMBERS		Qty.
		MODELS B, C & F	MODELS J, L & LL	MODELS R & RR	
1	SWIVEL SUSPENSION ASSEMBLY - W/ LATCH TYPE HOOK	2792NH	3661NH	3660NH	1
	SWIVEL SUSPENSION ASSEMBLY - W/ LATCHLOK TYPE HOOK	2796NH	3662NH	3663NH	
	RIGID SUSPENSION ASSEMBLY - W/ LATCH TYPE HOOK	2788NH	3651NH	3658NH	
	RIGID SUSPENSION ASSEMBLY - W/ LATCHLOK TYPE HOOK	2790NH	3652NH	-*	
1.1	SUSPENSION ADAPTER	00000218B	00000220B	00000221B	1
1.2	UPPER HOOK SUB-ASSEMBLY - LATCH TYPE	28689B	35617B	35616B	1
	UPPER HOOK SUB-ASSEMBLY - LATCHLOK TYPE	28643	36678	36680	
1.2.1	LATCH KIT	45661	45662	45663	-**
1.3	THRUST WASHER (FOR SWIVEL SUSPENSIONS ONLY)	27786	45930	45918	1
1.4	UPPER HOOK COLLAR FOR SWIVEL SUSPENSIONS	27350	35042	35041	1
	UPPER HOOK COLLAR FOR RIGID HOOK AND LUG SUSPENSIONS	27372	35458	35426	
1.5	SPRING PIN	27805	983764	983762	1
1.6	DEAD END BOLT	-	-	35957	1
1.7	DEAD END BLOCK	-	-	35418	1
1.8	DEAD END PIN	-	-	82314	1
1.9	WASHER	-	-	987877	1
1.10	COTTER PIN	-	-	988330	1
1.11	SUSPENSION SCREW	987554	36849	36849	2

*Contact factory for Latchlok hooks and assemblies

**Latch Type hooks assemblies come with latches installed

UPPER SUSPENSIONS – RRS

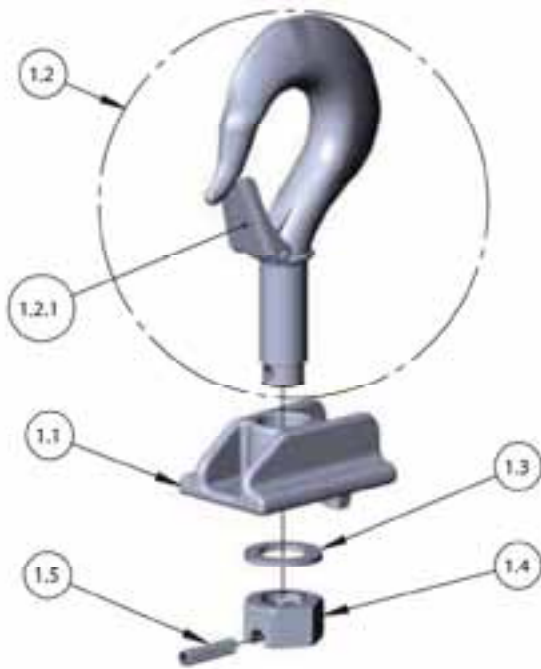

SWIVEL HOOK ASSEMBLY

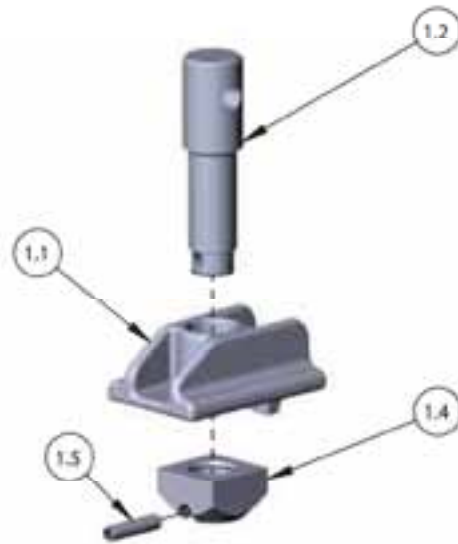

LUG ASSEMBLY

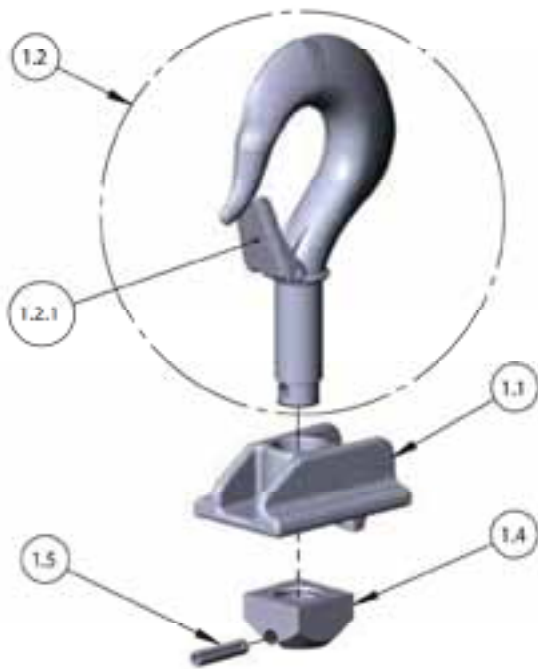

RIGID HOOK ASSEMBLY

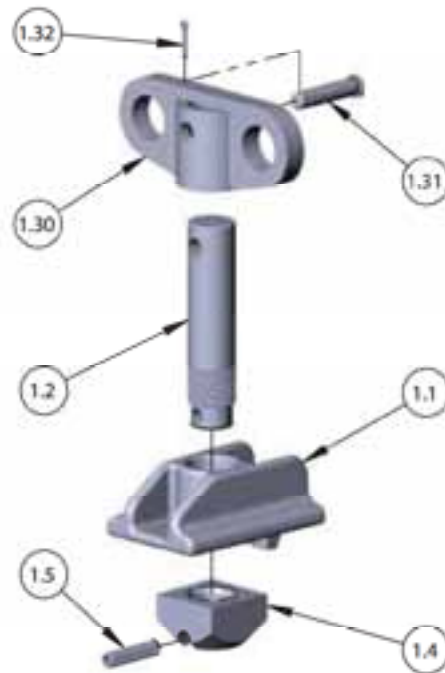

UNIVERSAL TROLLEY LUG ASSEMBLY

UPPER SUSPENSIONS-RRS

Item No.	Description	Part Numbers	Qty.
1	SWIVEL SUSPENSION ASSEMBLY - W/ LATCH TYPE HOOK	10001100	1
	SWIVEL SUSPENSION ASSEMBLY - W/ LATCHLOK TYPE HOOK	-*	
	RIGID SUSPENSION ASSEMBLY - W/ LATCH TYPE HOOK	10001101	
	RIGID SUSPENSION ASSEMBLY - W/ LATCH TYPE HOOK CROSS MOUNT	10001101X	
	RIGID SUSPENSION ASSEMBLY - W/LATCHLOK TYPE HOOK	-*	
	LUG SUSPENSION FOR LOW HEADROOM OR MOTOR DRIVEN TROLLEY	10001103	
	LUG SUSPENSION FOR LOW HEADROOM OR MOTOR DRIVEN TROLLEY CROSS MOUNT	10001103X	
	LUG SUSPENSION FOR UNIVERSAL TROLLEY	10001104	
	LUG SUSPENSION FOR UNIVERSAL TROLLEY CROSS MOUNT	10001104X	
1.1	SUSPENSION ADAPTER	10001050B	1
1.2	UPPER HOOK SUB-ASSEMBLY - LATCH TYPE	35616B	1
	UPPER HOOK SUB-ASSEMBLY - LATCHLOK TYPE	36680	
	SUSPENSION LUG FOR LOW HEADROOM OR MOTOR DRIVEN TROLLEY	35457	
	SUSPENSION LUG FOR UNIVERSAL TROLLEY	002508	
1.2.1	LATCH KIT	45663	1**
1.3	THRUST WASHER (FOR SWIVEL SUSPENSIONS ONLY)	35426	1
1.4	UPPER HOOK COLLAR FOR SWIVEL SUSPENSIONS	35041	1
	UPPER HOOK COLLAR FOR RIGID HOOK AND LUG SUSPENSIONS	45918	
1.5	SPRING PIN	983762	1
1.6	DEAD END BOLT	35957	1
1.7	DEAD END BLOCK	35418	1
1.8	DEAD END PIN	82314	1
1.9	WASHER	987877	1
1.10	COTTER PIN	988330	1
1.11	SUSPENSION SCREW	36849	2
1.30	LUG ADAPTER	00002503	1
1.31	LUG ADAPTER PIN	00002504	1
1.32	COTTER PIN	H5025P	1

*Contact factory for Latchlok hooks and assemblies

**Latch Type hooks assemblies come with latches installed

LOWER HOOK BLOCKS SINGLE REEVED

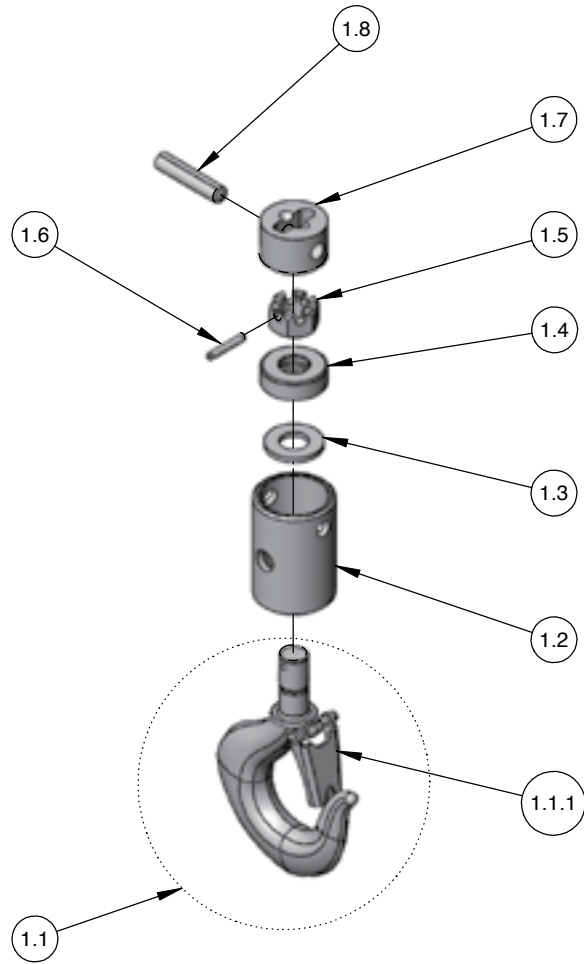

Item No.	Description	SINGLE-REEVED MODELS			Qty.
		A, A-2, AA, AA-2, B, B-2, C, C-2, F, F-2	J, J-2, L, L-2, LL, LL-2	RRS	
1	LOWER HOOK BLOCK ASSEMBLY-COMPLETE WITH LATCH TYPE HOOK	*28683	*35651	*10001052	1
1.1	LOWER HOOK WITH LATCH	28686	35611	35612B	1
	LATCHLOK TYPE HOOK	28604	28604	36681	
1.1.1	LATCH KIT	45661	45662	45663	1
1.2	LOWER HOOK BODY	45401B	35370	45399B	1
1.3	LOWER HOOK WASHER	945921	945921	N/A	1
1.4	LOWER HOOK THRUST BEARING	88485	88485	88505	1
1.5	LOWER HOOK NUT	982526	982526	35369	1
1.6	LOWER HOOK NUT PIN	983772	983772	45946	1
1.7	LOWER HOOK CHAIN BLOCK	28007	35026	10001054	1
1.8	LOWER HOOK CHAIN BLOCK PIN	45943	35790	45948	1

LOWER HOOK BLOCKS DOUBLE REEVED

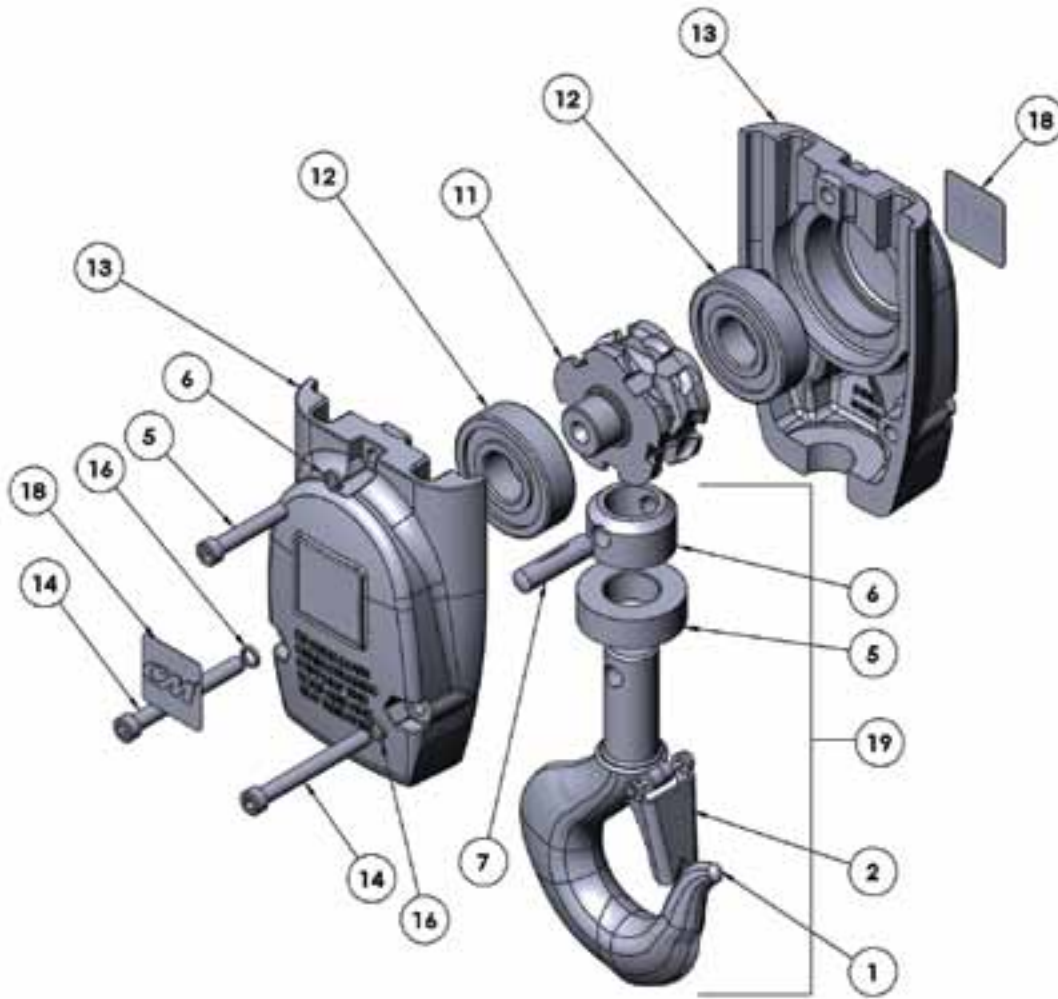

Item No.	Description	MODELS R & RR	Qty.
1	LOWER HOOK BLOCK ASSEMBLY-COMPLETE WITH LATCH TYPE HOOK	*00000277B	1
1.1	LOWER HOOK ASSEMBLY WITH LATCH AND BRG	35645	1
	LATCHLOK TYPE HOOK ASSEMBLY WITH BRG	-*	
1.1.1	LOWER HOOK WITH LATCH	35612B	1
	LATCHLOK TYPE HOOK	36681	
1.1.1.1	LATCH KIT	45663	1
1.1.2	LOWER HOOK THRUST BEARING	88505	1
1.1.3	LOWER HOOK COLLAR	35369	1
1.1.4	LOWER HOOK PIN	45946	1
1.2	HOOK BLOCK (ORDER IN PAIRS)	00000276B	2
1.3	HOOK BLOCK SHEAVE	00000274	1
1.4	HOOK BLOCK SHEAVE BEARING	83674	2
1.5	HOOK BLOCK SCREW-LONG	982374	2
1.6	HOOK BLOCK SCREW-SHORT	982370	1
1.7	HOOK BLOCK LOCKWASHER	940830	3
1.8	HOOK BLOCK NUT	982445	3
1.9	HOOK BLOCK LABEL	00000766	2

* Contact CM for LatchLok part numbers

LODESTAR DC BRAKE SINGLE MODELS B, C, & F

BACK FRAME
w/ DRIVE SHAFT
& O-RING

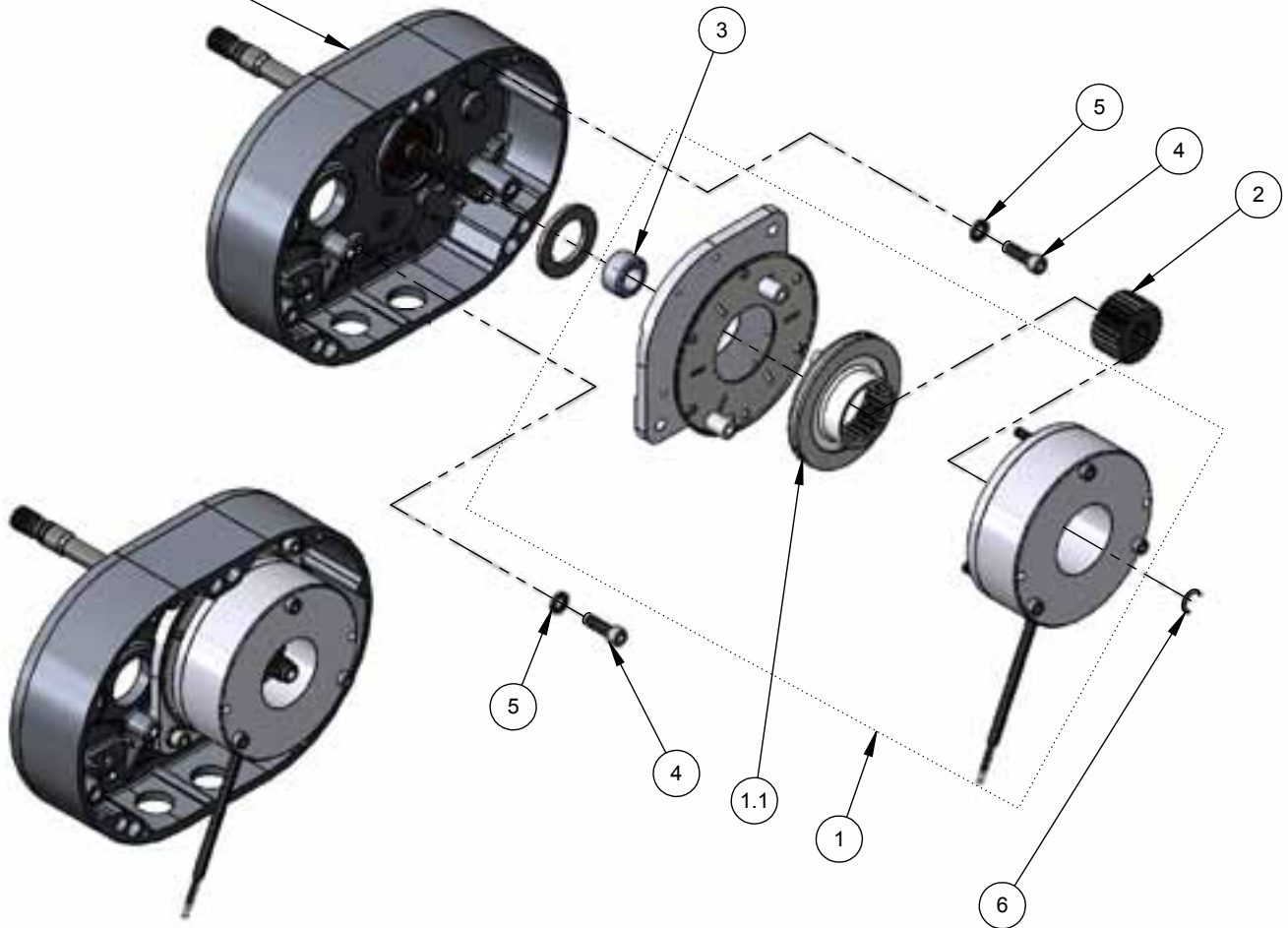

ASSEMBLED VIEW

BRAKE ASSEMBLY ITEM 1	HOIST MOTOR	BRAKE COIL VOLTAGE
10001243	110/115 -1-50/60	103VDC
10001244	220/230-1-50/60 220/230-3-50/60 380/415/480-3-50/60	205VDC

Item No.	PART NO.	DESCRIPTION	Qty.
1	10001243	V1 #8 BRAKE 103V	1
1.1	10001252	V1 LODESTAR, SIZE 8 ROTOR	1
2	00001430	V1 LODESTAR, SIZE 8 HUB	1
3	00001432	HUB SPACER V1 DC BRAKE	1
4	10001265	1/4-20 X 3/4 SKT HEAD SCREW	2
5	982226	LOCKWASHER 1/4 X .109 X .062"	2
6	10409710	ROTOR CLIP RETAINING RING	1

LODESTAR DC BRAKE SINGLE MODELS J, L, LL, RR & RRS

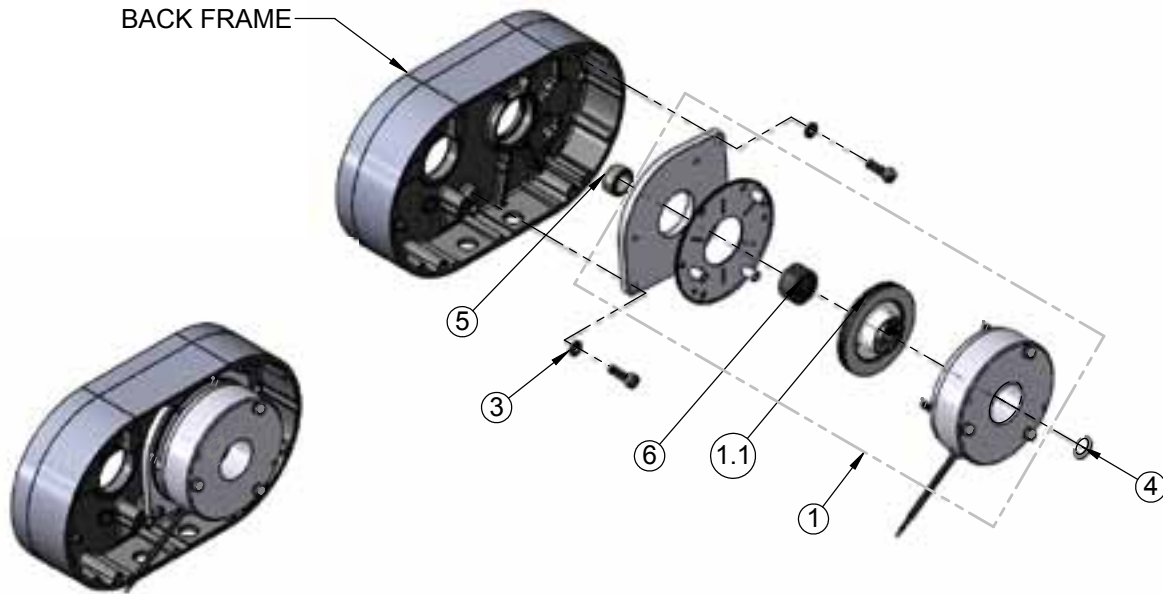

ASSEMBLED VIEW

HOIST MODEL	BRAKE ASSEMBLY ITEM 1	HOIST MOTOR	BRAKE COIL VOLTAGE
J, L, R	10001246	110/115-1-50/60 220/230-1-50/60	103VDC
	10001247	220/230-1-50/60 220/230-3-50/60 380/415/480-3-50/60	205VDC
LL, RR	10001249	220/230-3-50/60 380/415/480-3-50/60	205VDC

Item No.	PART NO.	DESCRIPTION	Qty.
1	SEE TABLE	V2 #10 BRAKE	1
1.1	10001253	V2 LODESTAR, SIZE 10 ROTOR	1
2	982709	SCREW 5/16-18 UNC-2A X 1"	2
3	945851	LOCKWASHER, 5/16 X .125 X .078	2
4	10409711	ROTOR CLIP RETAINING RING	1
5	00001433	HUB SPACER V2 DC INTORQ BRAKE	1
6	00001431	V2 LODESTAR, SIZE 10 HUB	1

LODESTAR DC BRAKE DOUBLE MODELS B, C, & F

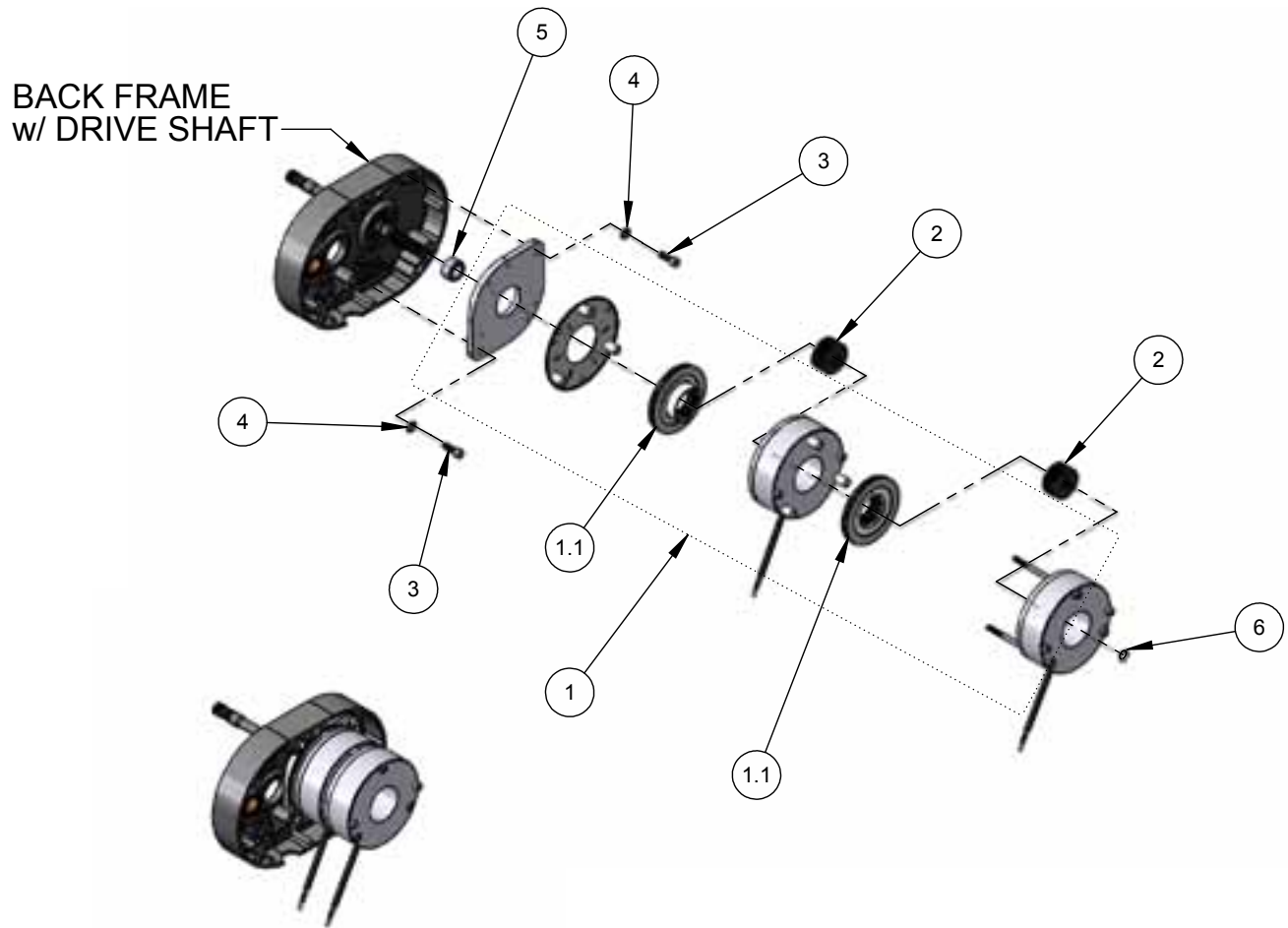

ASSEMBLED VIEW

BRAKE ASSEMBLY ITEM 1	HOIST MOTOR	BRAKE COIL VOLTAGE
10001446	220/230-1-50/60 220/230-3-50/60 380/415/480-3-50/60	205VDC

Item No.	PART NO.	DESCRIPTION	Qty.
1	SEE TABLE	V1 #8 DC BRAKE 255V	1
1.1	10001252	V1 LODESTAR, SIZE 8 ROTOR	2
2	00001430	V1 LODESTAR, SIZE 8 HUB	2
3	10001265	1/4-20 X 3/4 SKT HEAD SCREW	2
4	982226	LOCKWASHER 1/4 X .109 X .062"	2
5	00001432	HUB SPACER V1 DC BRAKE	1
6	27766	RING, SNAP WALDES 5100-40PP	1

LODESTAR DC BRAKE DOUBLE MODELS J, L, LL, R, RR & RRS

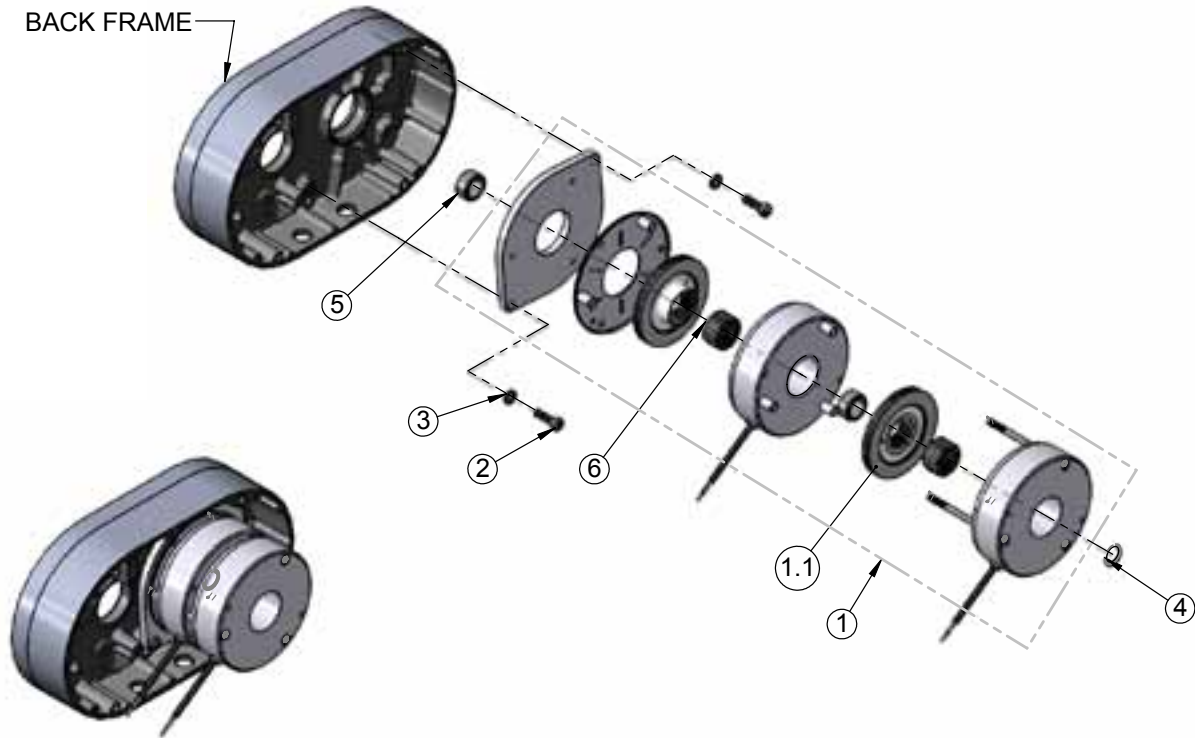

ASSEMBLED VIEW

HOIST MODEL	BRAKE ASSEMBLY ITEM 1	HOIST MOTOR	BRAKE COIL VOLTAGE
J, L, R	10001450	220/230-1-50/60 220/230-3-50/60 380/415/480-3-50/60	205VDC
LL, RR	10001452	220/230-3-50/60 380/415/480-3-50/60	205VDC

Item No.	PART NO.	DESCRIPTION	Qty.
1	SEE TABLE	#10 DOUBLE BRAKE	1
1.1	10001253	V2 LODESTAR, SIZE 10 ROTOR	2
2	982709	SCREW 5/16-18 UNC-2A X 1"	2
3	945851	LOCKWASHER, 5/16 X .125 X .078	2
4	35766	ROTOR CLIP RETAINING RING	1
5	00001433	HUB SPACER V2 DC INTORQ BRAKE	2
6	00001431	V2 LODESTAR, SIZE 10 HUB	2

LODESTAR DC BRAKE - SINGLE TO DOUBLE CONVERSION MODELS B, C, & F

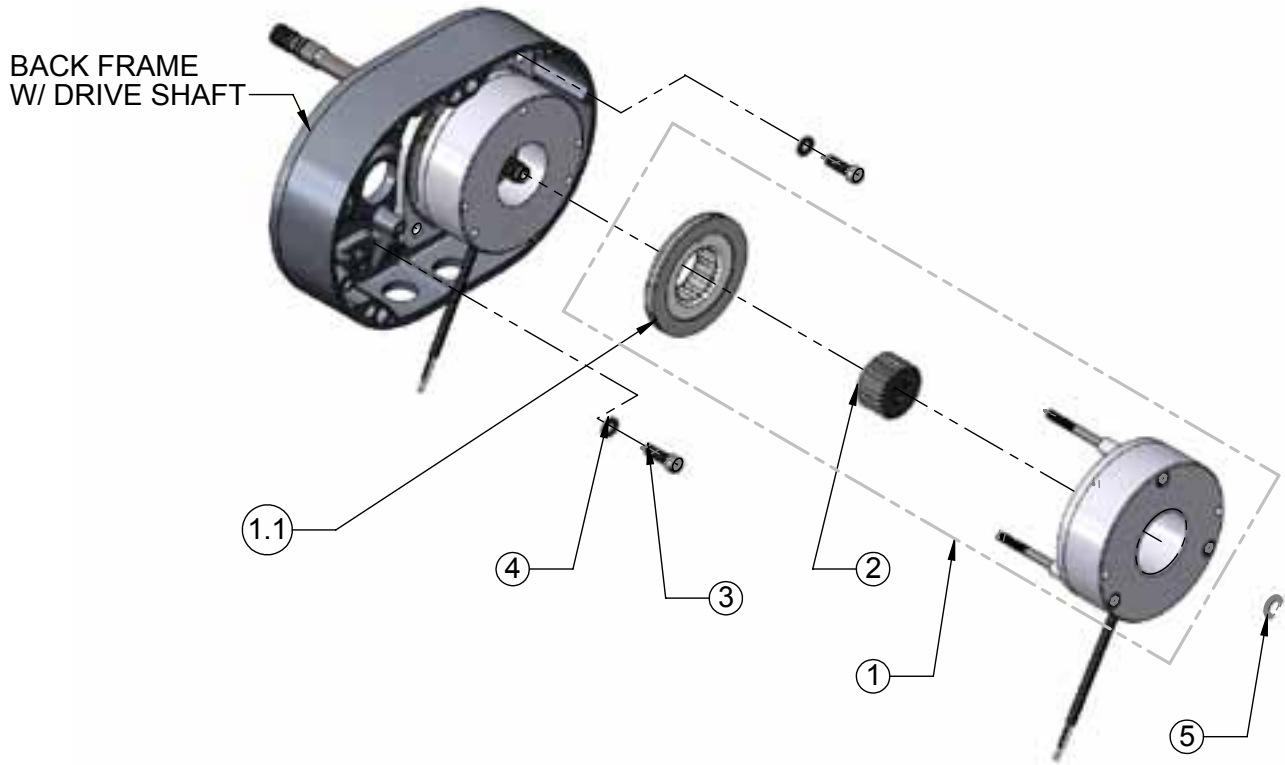

BRAKE ASSEMBLY ITEM 1	HOIST MOTOR	BRAKE COIL VOLTAGE
10001454	110/115-1-50/60	103VDC
10001455	220/230-1-50/60 220/230-3-50/60 380/415/480-3-50/60	205VDC

Item No.	PART NO.	DESCRIPTION	Qty.
1	SEE TABLE	V1 LODESTAR, SIZE 8 BRAKE	1
1.1	10001252	V1 LODESTAR, SIZE 8 ROTOR	1
2	00001430	V1 LODESTAR, SIZE 8 HUB	2
3	10001265	1/4-20 X 3/4 SKT HEAD SCREW	2
4	982226	LOCKWASHER 1/4 X .109 X .062"	2
5	27766	ROTOR CLIP RETAINING RING	1

LODESTAR DC BRAKE - SINGLE TO DOUBLE CONVERSION MODELS J, L, LL, R, RR & RRS

BACK FRAME W/
SINGLE DC BRAKE

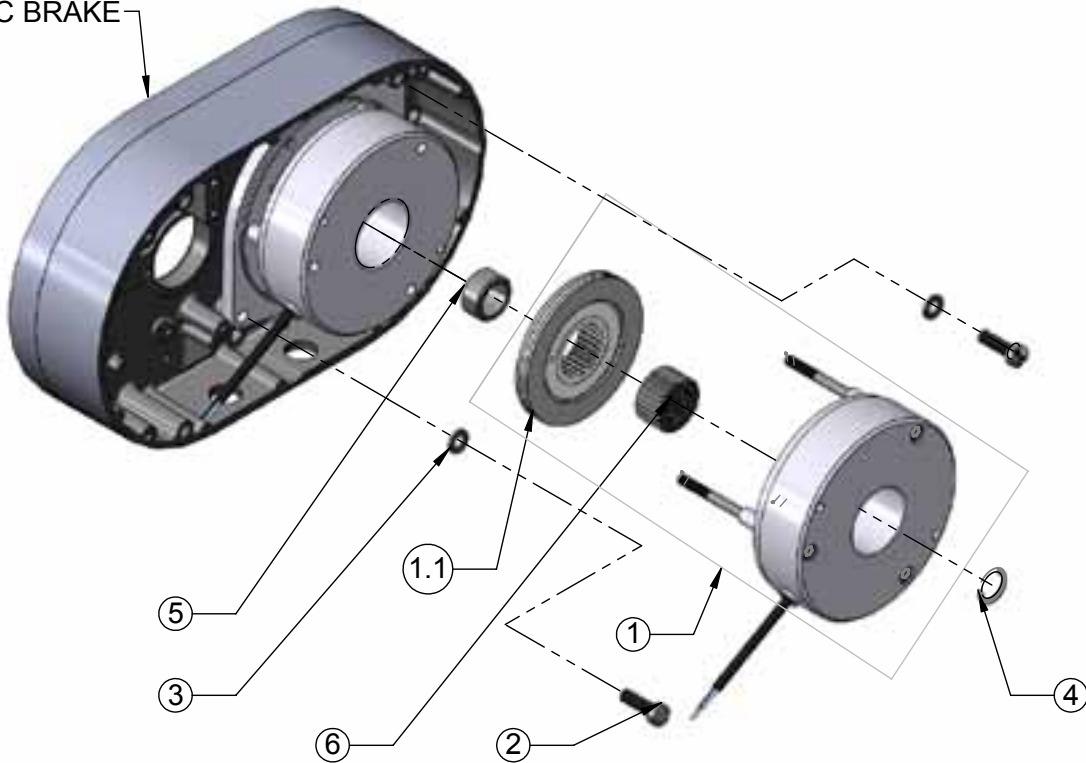

HOIST MODEL	BRAKE ASSEMBLY ITEM 1	HOIST MOTOR	BRAKE COIL VOLTAGE
J, L, R	10001457	110/115-1-50/60	103VDC
	10001458	220/230-1-50/60 220/230-3-50/60 380/415/480-3-50/60	205VDC
LL, RR	10001460	220/230-1-50/60 220/230-3-50/60 380/415/480-3-50/60	205VDC

Item No.	PART NO.	DESCRIPTION	Qty.
1	SEE TABLE	#10 DOUBLE BRAKE	1
1.1	10001253	V2 LODESTAR, SIZE 10 ROTOR	1
2	982709	SCREW 5/16-18 UNC-2A X 1"	2
3	945851	LOCKWASHER, 5/16 X .125 X .078	2
4	35766	ROTOR CLIP RETAINING RING	1
5	00001433	HUB SPACER V2 DC INTORQ BRAKE	1
6	00001431	V2 LODESTAR, SIZE 10 HUB	1

CONTACTOR PLATE ASSEMBLY FOR USE WITH DC BRAKE BHSE FUSED-3 PHASE 220/230-380/415/460-3-50/60 MODELS B, C, & F

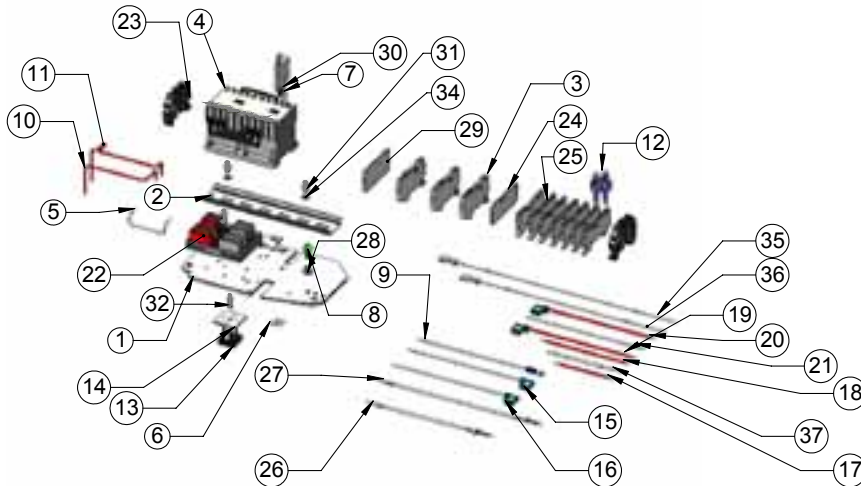

CONTACTOR BKT S/A	REVERSING CONTACTOR	SECONDARY VOLTAGE
10001638	28860	24 V
10001639	24797	48 V
10001640	24799	110 V

Item No.	PART NO.	DESCRIPTION	Qty.
1	10001649	V1 CONTACTOR PLATE	1
2	29010	DIN-RAIL 6.50" LONG	1
3	10001404	PT 2,5-TG DISCONNECT TERMINAL BLOCK	3
4	SEE TABLE	REVERSING CONTACTOR	1
5	51847	JUMPER	1
6	20940	GROUND LABEL	1
7	393	FUSE-5MM X 20MM-500MA	1
8	987827	SCREW 1/4-20 UNC-2A X 1/2"	1
9	27189	JUMPER (G-Y)	1
10	750	JUMPER WIRE	1
11	751	JUMPER WIRE	1
12	535	SURGE SUPPRESSOR	2
13	70246	RECTIFIER	1
14	70274	RECTIFIER INSULATOR	1
15	1500	B3 JUMPER	1
16	1501	B4 JUMPER	1
17	537	B8 JUMPER	1
18	538	B9 JUMPER	1
19	376	B5 JUMPER	1
20	205	B6 JUMPER	1
21	1504	B7-JUMPER	1
22	10001233	VOLTAGE CHANGE BOARD	1
23	909J13	END CLAMP	2
24	10001406	QUATTRO END COVER	1
25	10001403	QUATTRO FEED-THRU TERMINAL BLOCK	7
26	10001651	BRAKE JUMPER	1
27	10001650	BRAKE JUMPER	1
28	982226	LOCKWASHER 1/4 X .109 X .062	1
29	10001407	D-PT 2,5-MT END COVER	1
30	10001405	P-FU 5X20-5 FUSE PLUG	1
31	10001259	#10-32 x 5/16 BUTTON SKT HEAD	2
32	10001264	#6-32 1/2 BUTTON SKT HEAD	1
33	10001263	#8-32 X 1/2 BUTTON SKT HEAD	1
34	987873	LOCKWASHER #10 ASA MEDIUM	2
35	10001647	W4 JUMPER	1
36	10001648	W5 JUMPER	1
37	27645	JUMPER	1

CONTACTOR PLATE ASSEMBLY FOR USE WITH DC BRAKE SINGLE PHASE 110/115-1-50/60 MODELS A, AA, B, C, E & H

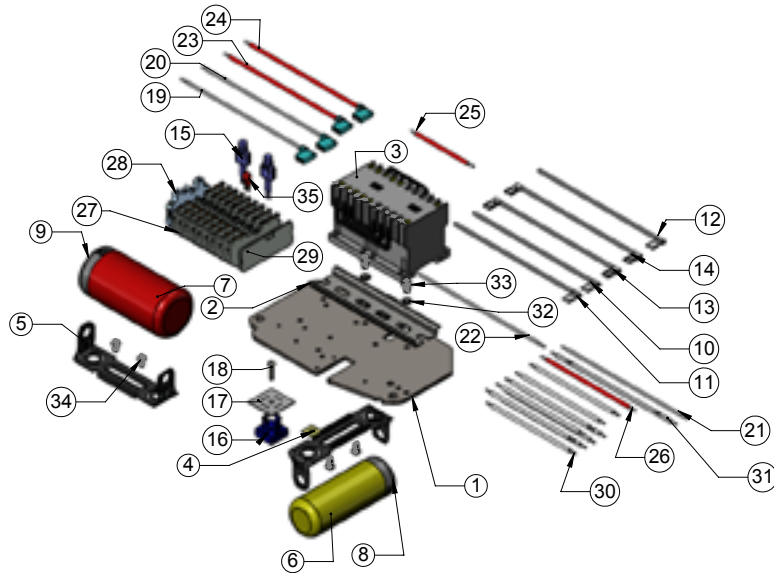

Item No.	PART NO.	DESCRIPTION	Qty.
1	10001649	V1 CONTACTOR PLATE	1
2	29312	DIN-RAIL 5.00" LONG	1
3	24799	REVERSING CONTACTOR	1
4	20940	GROUND LABEL	1
5	27910	CAPACITOR MOUNTING BRACKET	2
6	27716	CAPACITOR	1
7	27257	REVERSE SWITCH	1
8	29910	CAPACITOR CAP	1
9	27925	SOLID STATE SWITCH CAP	1
10	27156	JUMPER R14	1
11	29911	JUMPER R5	1
12	29912	JUMPER R6	1
13	29913	JUMPER R7	1
14	29914	JUMPER R8	1
15	535	SURGE SUPPRESSOR	2
16	70246	RECTIFIER	1
17	70274	INSULATOR, RECTIFIER	1
18	957854	SCREW #6-32 NC-2 X 5/8" ROUND	1
19	1500	B3 JUMPER	1
20	1501	JUMPER - B4	1
21	1504	B7-JUMPER	1
22	1502	JUMPER-B1	1
23	376	B5 JUMPER	1
24	205	B6 JUMPER	1
25	537	B8 JUMPER	1
26	538	B9 JUMPER	1
27	10001403	"QUATTRO FEED-THRU TERMINAL BLOCK"	9
28	10001408	CLIPFIX 35-5 END CLAMP	1
29	10001406	QUATTRO END COVER	1
30	51847	JUMPER	9
31	321	R13 JUMPER	1
32	987873	LOCKWASHER #10 ASA MEDIUM	2
33	10001259	#10-32 x 5/16 BUTTON SKT HEAD	2
34	10001260	#8-32 X 5/16 BUTTON SKT HEAD	4
35	10001425	JUMPER FBS 2-3,5	1

CONTACTOR PLATE ASSEMBLY FOR USE WITH DC BRAKE BHSE 3 PHASE 220/230-380/415/460-3-50/60 MODELS B, C, & F

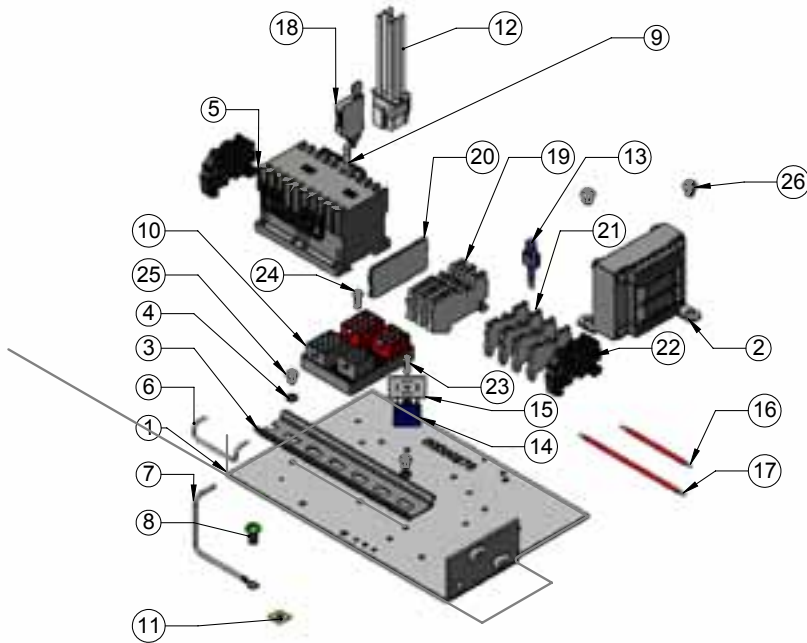

CONTACTOR BKT S/A	TRANSFORMER	REVERSING CONTACTOR	SECONDARY VOLTAGE
00001722	00000594T	28860	24 V
00001723	00000595T	24797	48 V
00001724	00000596T	24799	110 V

Item No.	PART NO.	DESCRIPTION	Qty.
1	278	CONTACTOR BRACKET	1
2	SEE TABLE	TRANSFORMER	1
3	29010	DIN-RAIL 6.50" LONG	1
4	987873	LOCKWASHER #10 ASA MEDIUM	2
5	SEE TABLE	REVERSING CONTACTOR	1
6	51847	JUMPER	1
7	27189	JUMPER (G-Y)	1
8	987827	SCREW 1/4-20 UNC-2A X 1/2"	1
9	393	FUSE-5MM X 20MM-500MA	1
10	10001233	VOLTAGE CHANGE BOARD	1
11	20940	GROUND LABEL	1
12	1733	HARNESS V2/CONTACTOR	1
13	535	SURGE SUPPRESSOR	1
14	70246	RECTIFIER	1
15	70274	INSULATOR, RECTIFIER	1
16	537	B8 JUMPER	1
17	538	B9 JUMPER	1
18	10001405	P-FU 5X20-5 FUSE PLUG	1
19	10001404	"PT 2,5-TG DISCONNECT TERMINAL	
BLOCK"	3		
20	10001407	D-PT 2,5-MT END COVER	1
21	10001401	"PT 1,5/S FEED-THROUGH	
TERMINAL BLOCK"	4		
22	909J13	END CLAMP	2
23	10001264	#6-32 1/2 BUTTON SKT HEAD	1
24	10001263	#8-32 X 1/2 BUTTON SKT HEAD	1
25	10001259	#10-32 x 5/16 BUTTON SKT HEAD	2
26	10001262	1/4-20 X 5/16 BUTTON SKT HEAD	2

CONTACTOR PLATE ASSEMBLY FOR USE WITH DC BRAKE SINGLE PHASE 110/115-1-50/60 MODELS J, L, & R

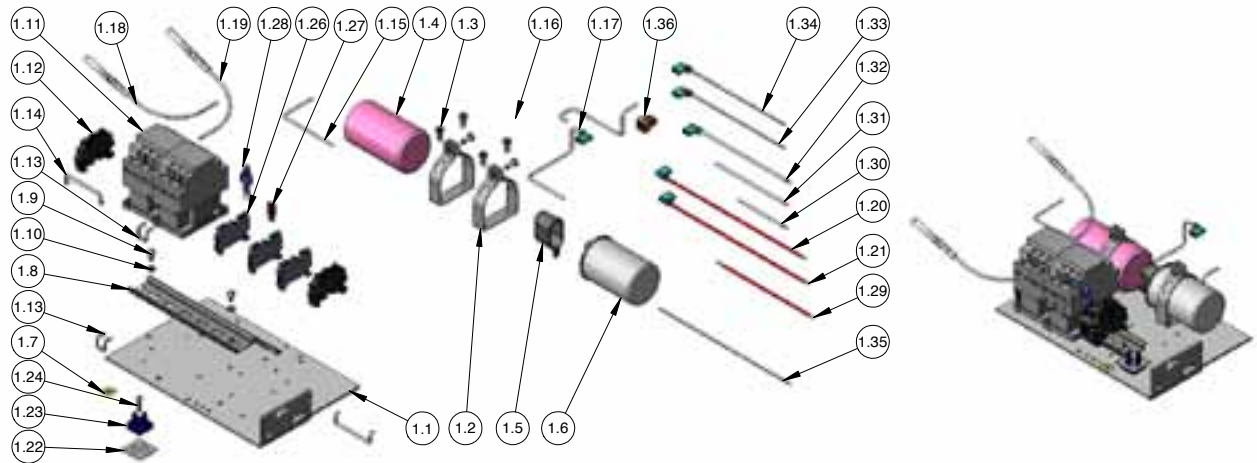

Item No.	PART NO.	DESCRIPTION	Qty.
1	00001695	CONTACTOR BRACKET S/A	1
1.1	00000278	CONTACTOR BRACKET	1
1.2	35268	CLAMP	2
1.3	10001261	#10-24 X 3/16 BUTTON SKT HEAD SCREW	6
1.4	35279	START CAPACITOR	1
1.5	35285	RUN CAPACITOR INSULATOR	1
1.6	35278	CAPACITOR, RUN	1
1.7	20940	GROUND LABEL	1
1.8	29010	DIN-RAIL 6.50" LONG	1
1.9	10001259	#10-32 X 5/16 BUTTON SKT HEAD SCREW	2
1.10	987873	LOCKWASHER #10 ASA MEDIUM	2
1.11	28905	REVERSING CONTACTOR	1
1.12	909J13	END CLAMP	2
1.13	51845	JUMPER	2
1.14	51847	JUMPER	2
1.15	29035	JUMPER (R4)	1
1.16	29034	JUMPER (R10)	1
1.17	00000758	JUMPER V2 1 PHASE (R9)	1
1.18	29036	JUMPER (R2)	1
1.19	29037	JUMPER (R3)	1
1.20	00000755	JUMPER V2 1 PHASE (R7)	1
1.21	00000757	JUMPER V2 1 PHASE (R6)	1
1.22	70274	INSULATOR, RECTIFIER	1
1.23	70246	RECTIFIER	1
1.24	10001264	#6-32 X 1/2 BUTTON SKT HEAD SCREW	1
1.25	982470	HEX HEAD MACHINE NUT	1
1.26	29014	TERMINAL STRIP	3
1.27	29047	TERMINAL STRIP BRIDGE	1
1.28	00001505	SURGE SUPPRESSOR	1
1.29	00000336	JUMPER (R12)	1
1.30	00000537	B8 JUMPER	1
1.31	00000538	B9 JUMPER	1
1.32	00000376	B5 JUMPER	1
1.33	00001500	B3-JUMPER	1
1.34	00001501	JUMPER - B4	1
1.35	00001503	JUMPER-B2	1
1.36	11782704	CONNECTOR PUSHWIRE ORANGE	1

CONTACTOR PLATE ASSEMBLY FOR USE WITH DC BRAKE DIRECT CONTROL 380/415/460-3-50/60 MODELS J, L, LL, R, & RR

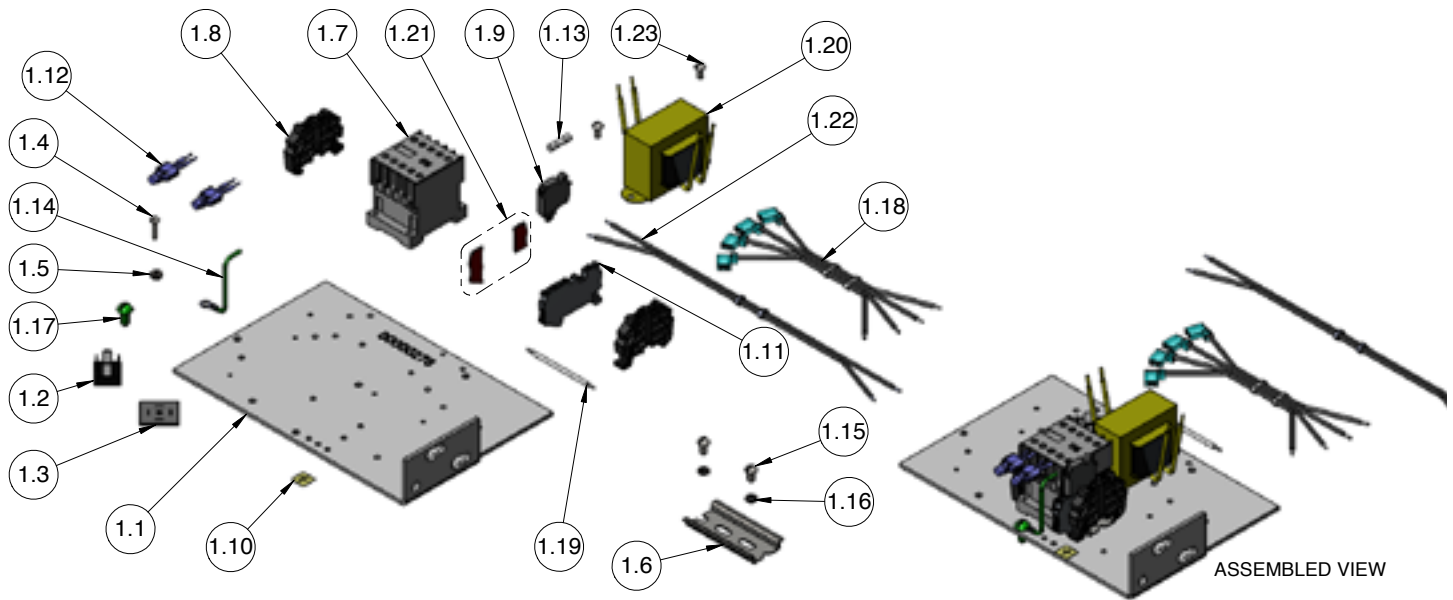

Item No.	PART NO.	DESCRIPTION	Qty.
1.1	10001118	CONTACTOR PLATE S/A	1
1.1	00000278	CONTACTOR BRACKET	1
1.2	70246	RECTIFIER	1
1.3	70274	RECTIFIER INSULATOR	1
1.4	10001264	#6-32 X 1/2 BUTTON SKT HEAD SCREW	1
1.5	982470	NUT #6-32 UNC-2A HEX MACHINE	1
1.6	00000323	DIN RAIL 2.75" LONG	1
1.7	28904	CONTACTOR, NON-REVERSING	1
1.8	909J13	END CLAMP	2
1.9	29019	TERMINAL STRIP CARTRIDGE	1
1.10	20940	GROUND LABEL	1
1.11	29018	FUSIBLE TERMINAL STRIP	1
1.12	00000535	SURGE SUPPRESSOR	2
1.13	00000393	FUSE-5MM X 20MM-500MA	1
1.14	27189	JUMPER-G/Y-#16 AWG	1
1.15	10001259	10-32 X 5/16 BUTTON SKT HEAD SCREW	2
1.16	987873	LOCKWASHER #10 ASA MEDIUM	2
1.17	987827	SCREW 1/4-20 UNC-2A X 1/2"	1
1.18	00000326	RECTIFIER HARNESS	1
1.19	51845	JUMPER	1
1.20	10001114	TRANSFORMER	1
1.21	00000398	TERMINAL STRIP COVER SEGMENT	1
1.22	00000827	'H5/H6' JUMPER HARNESS	1
1.23	10001260	#8-32 X 5/16 BUTTON SKT HEAD SCREW	2

CONTACTOR PLATE ASSEMBLY FOR USE WITH DC BRAKE DIRECT CONTROL 3 80/415/460-3-50/60 MODELS B, C, & F

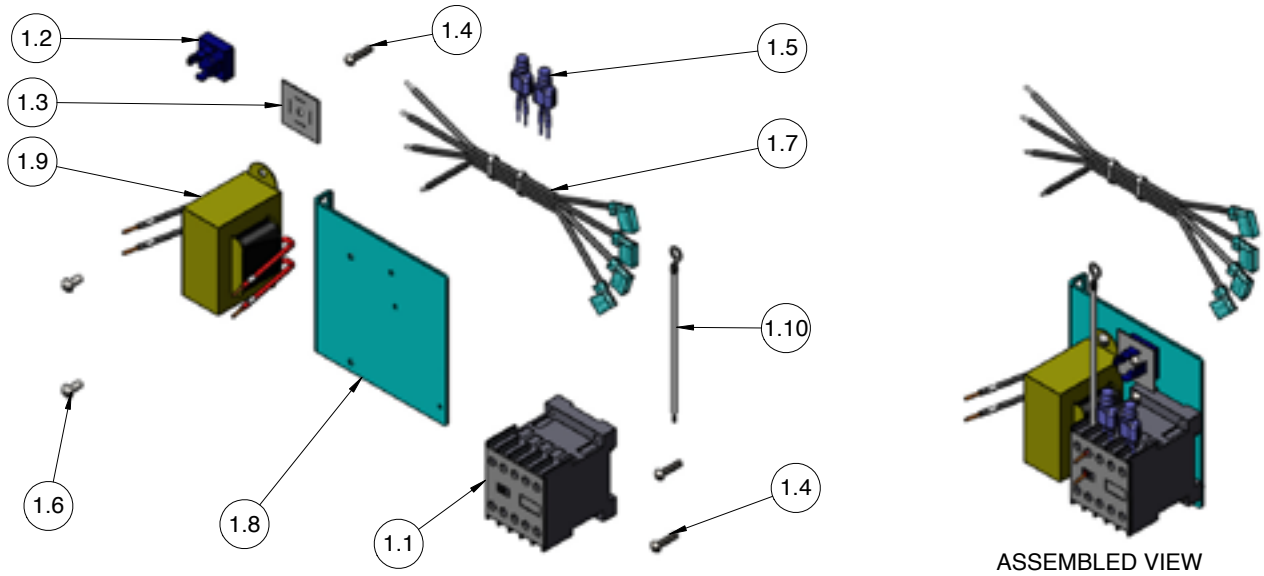

Item No.	PART NO.	DESCRIPTION	Qty.
1.7.1	10001121	CONTACTOR PLATE S/A	1
1.1	35928	MAINLINE CONTACTOR	1
1.2	70246	RECTIFIER	1
1.3	70274	INSULATOR, RECTIFIER	1
1.4	10001264	#6-32 X 1/2 BUTTON SKT HEAD SCREW	3
1.5	00001505	SURGE SUPPRESSOR	2
1.6	10001260	#8-32 X 5/16 BUTTON SKT HEAD SCREW	2
1.7	00000326	RECTIFIER HARNESS	1
1.8	10001120	CONTACTOR PLATE	1
1.9	10001119	TRANSFORMER	1
1.10	27189	G-Y JUMPER	1

CONTACTOR PLATE ASSEMBLY FOR USE WITH DC BRAKE 220/230-380/415/460-3-50/60 MODELS: RRS

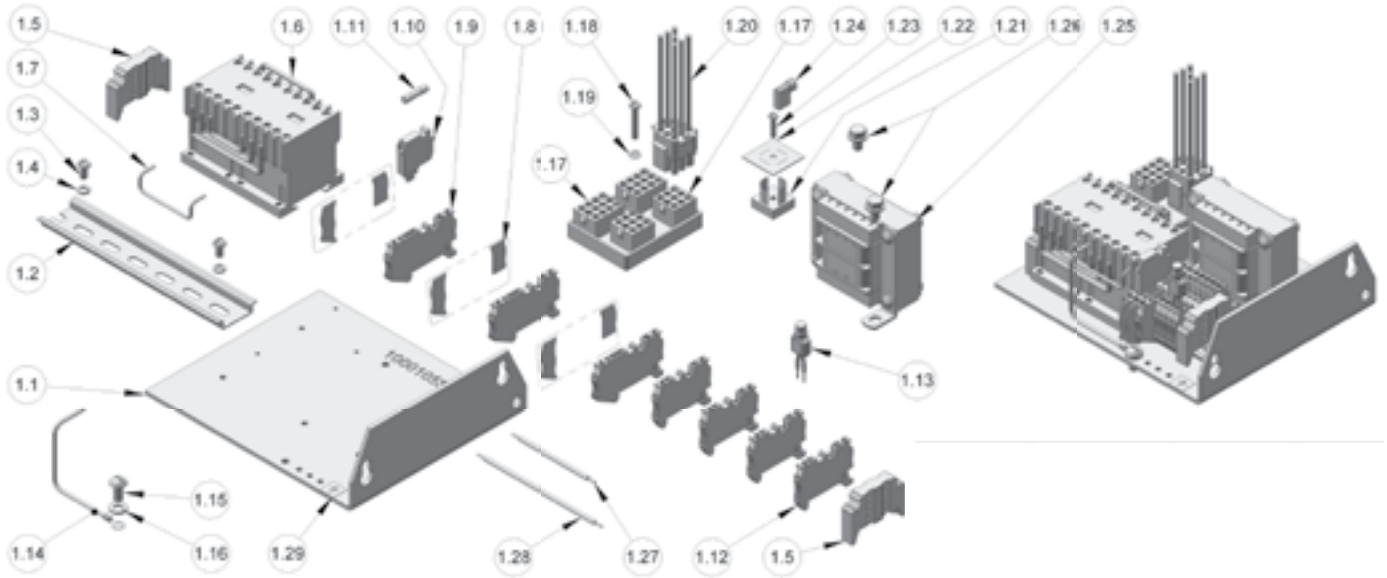

CONTACTOR BKT S/A	TRANSFORMER	REVERSING CONTACTOR	SECONDARY VOLTAGE
10001064	00000594T	28860	24 V
10001065	00000595T	24797	48 V
10001066	00000596T	24799	110 V

ITEM NO.	PART NUMBER	DESCRIPTION	QTY.
1	SEE TABLE	CTRLS ASSY-DUAL VOLTAGE	1
1.1	10001055	CONTACTOR CONTROLS BRACKET	1
1.2	29010	DIN-RAIL 6.50" LONG	1
1.3	10001259	#10-32 X 5/16 BUTTON SKT HEAD SCREW	2
1.4	987873	LOCKWASHER #10 ASA MEDIUM	2
1.5	29015	TERMINAL STRIP END CLAMP	2
1.6	SEE TABLE	REVERSING CONTACTOR	1
1.7	51847	JUMPER	1
1.8	00000398	TERMINAL STRIP COVER SEGMENT	3
1.9	29018	FUSIBLE TERMINAL STRIP	3
1.10	29019	TERMINAL STRIP CARTRIDGE	1
1.11	00000393	FUSE-5MM X 20MM-500MA	1
1.12	29014	TERMINAL STRIP	4
1.13	00000535	SURGE SUPPRESSOR	1
1.14	27189	JUMPER-G/Y-#16 AWG	1
1.15	987827	SCREW 1/4-20 UNC-2A X 1/2"	1
1.16	982226	LOCKWASHER 1/4 X .109 X .062"	1
1.17	10001233	VOLTAGE CHANGE BOARD	1
1.18	10001263	#6-32 X 1/2 BUTTON SKT HEAD SCREW	1
1.19	957844	LOCKWASHER	1
1.20	00001733	HARNESS V2/CONTACTOR	1
1.21	70246	RECTIFIER	1
1.22	70274	INSULATOR, RECTIFIER	1
1.23	10001264	#6-32 X 1/2 BUTTON SKT HEAD SCREW	1
1.24	983197	WIRING TERMINAL	1
1.25	SEE TABLE	TRANSFORMER-V2-230/460 PRIMARY	1
1.26	10001262	1/4-20 X 5/16 BUTTON SKT HEAD SCREW	2
1.27	00000537	B8 JUMPER	1
1.28	00000538	B9 JUMPER	1
1.29	20940	GROUND LABEL	1

**CONTACTOR PLATE ASSEMBLY FOR USE WITH DC BRAKE
DIRECT CONTROL 380/415/460-3-50/60 MODELS: RRS**

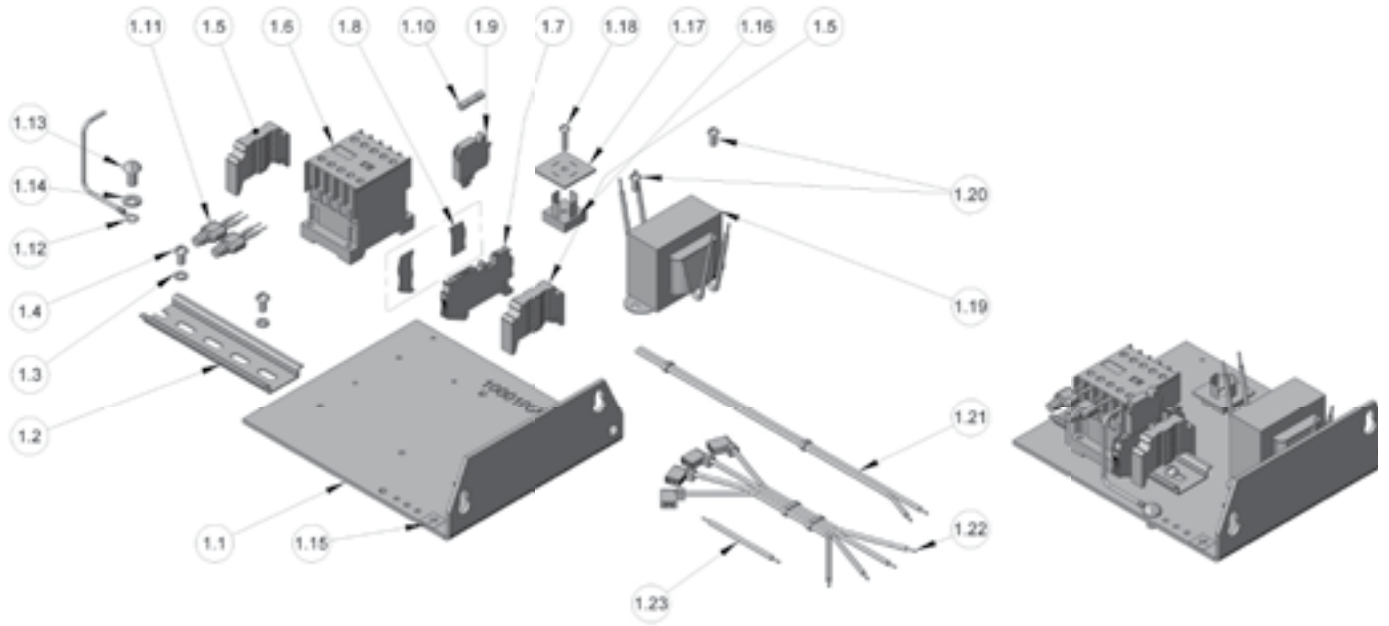

ITEM NO.	PART NUMBER	DESCRIPTION	QTY.
1	10001070	CTRLS ASSY-DUAL VOLTAGE	1
1.1	10001055	CONTACTOR CONTROLS BRACKET	1
1.2	29009	DIN-RAIL 6.50" LONG	1
1.3	987873	LOCKWASHER #10 ASA MEDIUM	2
1.4	10001259	#10-32 X 5/16 BUTTON SKT HEAD SCREW	2
1.5	29015	TERMINAL STRIP END CLAMP	2
1.6	28904	NON-REVERSING CONTACTOR	1
1.7	29018	FUSIBLE TERMINAL STRIP	1
1.8	00000398	TERMINAL STRIP COVER SEGMENT	1
1.9	29019	TERMINAL STRIP CARTRIDGE	1
1.10	00000393	FUSE-5MM X 20MM-500MA	1
1.11	00000535	SURGE SUPPRESSOR	2
1.12	27189	GROUND JUMPER	1
1.13	987827	SCREW 1/4-20 UNC-2A X 1/2"	1
1.14	982226	LOCKWASHER 1/4 X .109 X .062"	1
1.15	20940	GROUND LABEL	1
1.16	70246	RECTIFIER	1
1.17	70274	INSULATOR, RECTIFIER	1
1.18	10001264	#6-32 X 1/2 BUTTON SKT HEAD SCREW	1
1.19	10001114	TRANSFORMER	1
1.20	10001260	#8-32 X 5/16 BUTTON SKT HEAD SCREW	2
1.21	10001117	H5/H6 JUMPER HARNESS	1
1.22	00000326	RECTIFIER HARNESS	1
1.23	51845	JUMPER	1

SINGLE PHASE TERMINAL STRIP ASSEMBLY MODELS J, L, LL, R, RR AND RRS

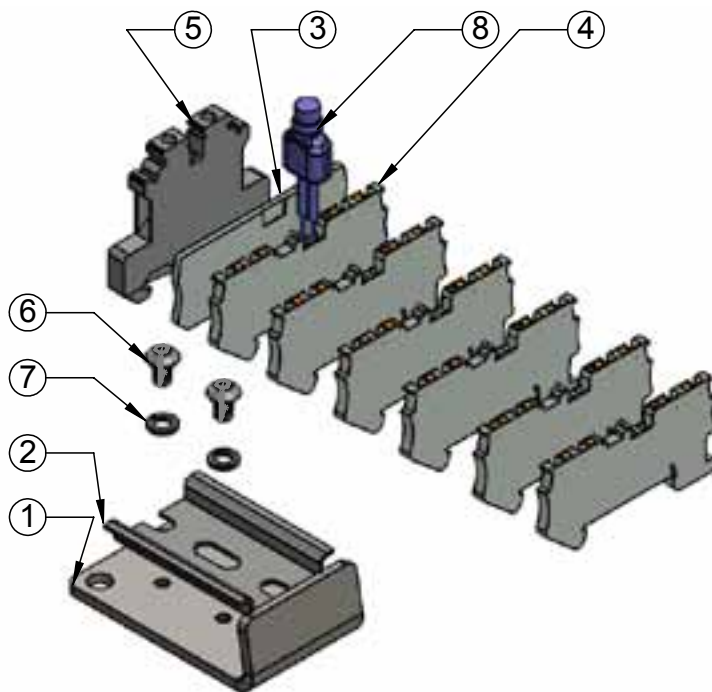

ITEM NO.	PART NUMBER	DESCRIPTION	QTY.
1	10001409	MOUNTING BRACKET	1
2	10001466	DIN-RAIL 2.0" LONG	1
3	10001406	QUATTRO END COVER	1
4	10001403	QUATTRO FEED-THRU TERMINAL BLOCK	6
5	10001433	GROUNDING BLOCK GREEN/YELLOW	1
6	10001259	#10-32 x 5/16 BUTTON SKT HEAD	2
7	987873	LOCKWASHER #10 ASA MEDIUM	2
8	535	SURGE SUPPRESSOR	1

THREE PHASE TERMINAL STRIP ASSEMBLY MODELS J, L, LL, R, RR AND RRS

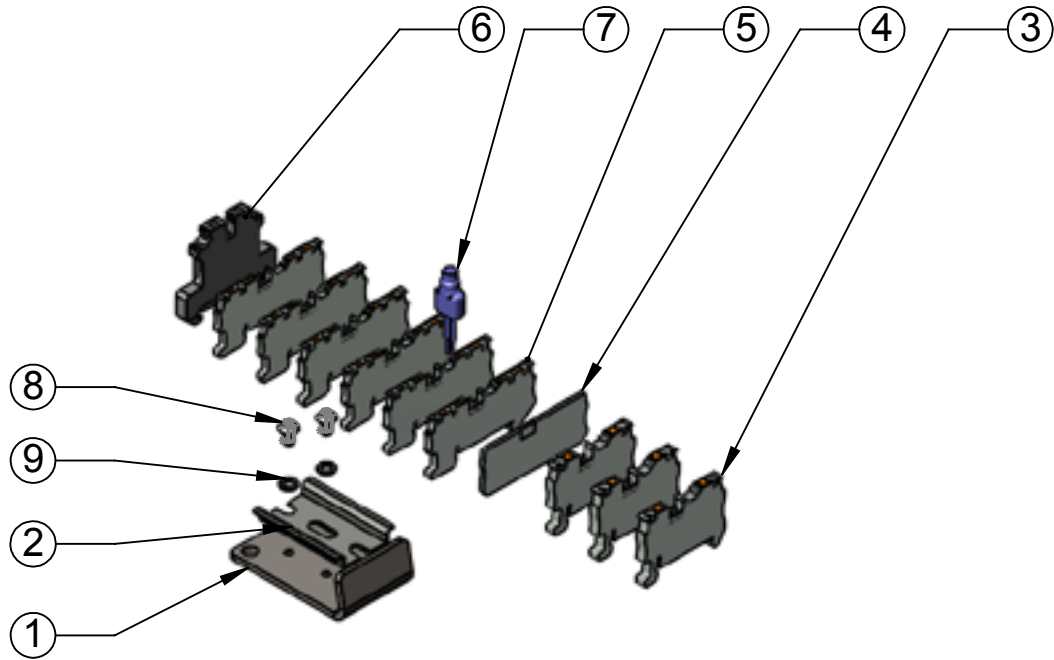

ITEM NO.	PART NUMBER	DESCRIPTION	QTY.
1	10001409	MOUNTING BRACKET	1
2	10001466	DIN-RAIL 2.0" LONG	1
3	10001424	TERMINAL BLOCK-FEED THRU	3
4	10001406	QUATTRO END COVER	1
5	10001403	QUATTRO FEED-THRU TERMINAL BLOCK	6
6	10001433	GROUNDING BLOCK GREEN/YELLOW	1
7	535	SURGE SUPPRESSOR	1
8	10001259	#10-32 x 5/16 BUTTON SKT HEAD	2
9	987873	LOCKWASHER #10 ASA MEDIUM	2

LUBRICANTS

Part Number for Packaged Lubricants Used in the Lodestar Electric Chain Hoists (Refer to page 14 for Lubrication Instructions)		
Lubricant Usage	Type of Lubricant	Part Numbers and Packaged Quantity of Lubricants
Hoist Gears	Grease (Special)	Models A to H uses 28605
		Model J to RRT excluding RRS uses 28617
		Model RRS uses 1 each of both 28605 and 28617
Load Chain	Oil	28608 for 1 Pint Can 28619 for 1 Gal Can
Limit Switch Shaft Threads	*Oil	"3 in 1" or Light Machine Oil-obtain locally
Lower Hook Thrust Bearing	*Oil	Heavy Machine Oil obtain locally

*These oils are not furnished by CM in Packaged Quantities. When ordering lubricants, specify the type of lubricant, part number and packages quantity required.

Touch-up Paints for Lodestar Electric Chain Hoists:

Hoist Order *(1) case (12-12 oz. Aerosol Cans) of Black Touch-up paints Part Number 84189.

*Touch-up paints are only available in case quantities.

NOTE: When painting hoists, also order warning labels, identification labels, etc. that may be coated during painting.

RECOMMENDED SPARE PARTS

To insure continued service of the Lodestar Hoist, the following is a list of parts that are recommended to be kept on hand at all times to replace parts that have worn or failed.

Part Description	Models A-H	Models J-RRT (excludes RRS)	Model RRS	Qty Required for Each Hoist
Limit Switch Kit	31631	31636	31636	1
Solid State Reverse Switch (Single Phase Units Only)	27257	35499	n/a	1
Start Capacitor (Single Phase Units Only)	27716	35279	n/a	1
Run Capacitor (Single Phase Units Only)	-	35278	n/a	
Transformer	SEE CONTACTOR PLATE SECTION	SEE CONTACTOR PLATE SECTION	SEE CONTACTOR PLATE SECTION	0 or 1
Control Station Hardware Kit w/ Gasket	SEE CONTROLS SECTION	SEE CONTROLS SECTION	SEE CONTROLS SECTION	1
Control Station Button Insert Kit	SEE CONTROLS SECTION	SEE CONTROLS SECTION	SEE CONTROLS SECTION	1
Contactors	SEE CONTACTOR PLATE SECTION	SEE CONTACTOR PLATE SECTION	SEE CONTACTOR PLATE SECTION	1
Fuse - 500mA	00000393	00000393	00000393	
Speed Selector Relay (2-Speed Units Only)	SEE CONTACTOR PLATE SECTION	SEE CONTACTOR PLATE SECTION	SEE CONTACTOR PLATE SECTION	1
CM Terminal Pin-Extraction Tool (Dual Voltage Only)	27163	27163	27163	1
Suspension Bolts	987554	36846	10001047/82638	2(1 EA RRS)



COLUMBUS McKINNON
CORPORATION

FAMILY OF BRANDS



USA: Ph: (800) 888.0985 • (716) 689.5400 • Fax: (716) 689.5644

CANADA: Ph: (877) 264.6478 • Fax: (877) 264.6477