

**GENERAL INFORMATION**

Hands-on foundational lighting control console with manual 2-scene preset operation, industry-acclaimed ETC Expression software and functionality.

- APPLICATIONS**
- College
  - Middle/High School
  - Community Theatre
  - Trade Show
  - Small TV Studio
  - Church
- FEATURES**
- Preset style operation
  - 192 Channels
  - 1024 DMX outputs
  - 600 Cues
  - 500 Groups
  - 2000 Macros
  - 10 pages of 24 Submasters
  - Two scene preset or preprogrammed operation
  - Preset Focus points
  - Moving Light features
  - LTP (Latest Takes Preisdence) Channels
  - Spreadsheet Editing
  - Ethernet for DMX, Video and other signal distribution
  - MIDI, MIDI Show Control and MIDI Time Code interface
  - Supports ETCLink Dimmer feedback
- ACCESSORIES**
- Video Node
  - DMX Node
  - Remote Focus Unit (RFU)
  - Gooseneck Lamps
  - Expression Offline
  - Expression Offline for Windows
  - Express LPC

**ORDERING INFORMATION**

**Express**

| Model#     | Description             |
|------------|-------------------------|
| EXPS 48/96 | Express 48/96           |
| LPC/192    | Express 192 Channel LPC |

**Express Accessories**

| Model#    | Description                       |
|-----------|-----------------------------------|
| DNODE-RF  | DMX Node - rack mount front entry |
| DNODE-RB  | DMX Node - rack mount rear entry  |
| DNODE-W   | DMX Node - wallbox mount          |
| VNODE-R   | Video Node                        |
| RFU       | Remote Focus Unit                 |
| M218      | VGA Color Monitor                 |
| M219      | LCD Flat Screen Display           |
| 4000A4003 | Monitor Dust Cover for M218       |
| M715      | Littlelite Work Light             |
| M604      | Parallel Printer                  |
| EOL       | Expression Offline                |

**Other Consoles in Express Family**

| Model#      | Description             |
|-------------|-------------------------|
| EXPS 24/48  | Express 24/48           |
| EXPS 72/144 | Express 72/144          |
| EXPS 125    | Express 125             |
| EXPS 250    | Express 250             |
| LPC/96      | Express 96 Channel LPC  |
| LPC/250     | Express 250 Channel LPC |



## SPECIFICATIONS

|                           |  |
|---------------------------|--|
| <b>GENERAL</b>            | 192 channels<br>1,024 DMX512 dimmers<br>600 cues<br>500 groups<br>99 focus points<br>Effects with up to 100 steps each<br>2,000 macros<br>24 submasters x 10 pages<br>2 timed/manual fader pairs<br>Diskette drive<br>Single VGA output<br>Printer port<br>UL, cUL, CE listed  |
| <b>DISPLAY FUNCTIONS</b>  | (Requires VGA monitor)<br>Cue List<br>Stage<br>Blind<br>Fader status<br>Spreadsheets and Lists<br>Cue, Sub, Group and Focus point views<br>Patch<br>Proportional levels<br>32 user-definable profiles<br>Dimmer Doubling capability (see Dimmer Doubling data sheet)<br>Setup<br>Flexichannel (displays only used channels)  |
| <b>PLAYBACK CONTROLS</b>  | Faders<br>2 Timed/manual fader pairs with Go, Hold, Rate, Clear, and Back buttons<br>Individual last action fade capability for every channel<br>Trackpad<br>Master slider<br>Blackout button<br>96 Channel faders<br>48 channel two-scene operation<br>96 channel single-scene operation<br>Individual bump buttons<br>Submasters<br>24 submasters (times 10 pages) with bump buttons and integral LEDs   |
| <b>OPTIONAL EQUIPMENT</b> | DMX Node<br>ETCNet 2 device with remote DMX output, RFU<br>Video Node<br>ETCNet 2 device with keyboard, RFU, VGA, Printer ports, Serial<br>Remote Focus Unit<br>Hand held device with a keypad and LCD screen accesses most system functions for local adjustments and show editing<br>Expression Off-Line<br>Available for free download from ETC via <a href="http://www.etcconnect.com">www.etcconnect.com</a><br>Parallel Printer<br>VGA Monitor |



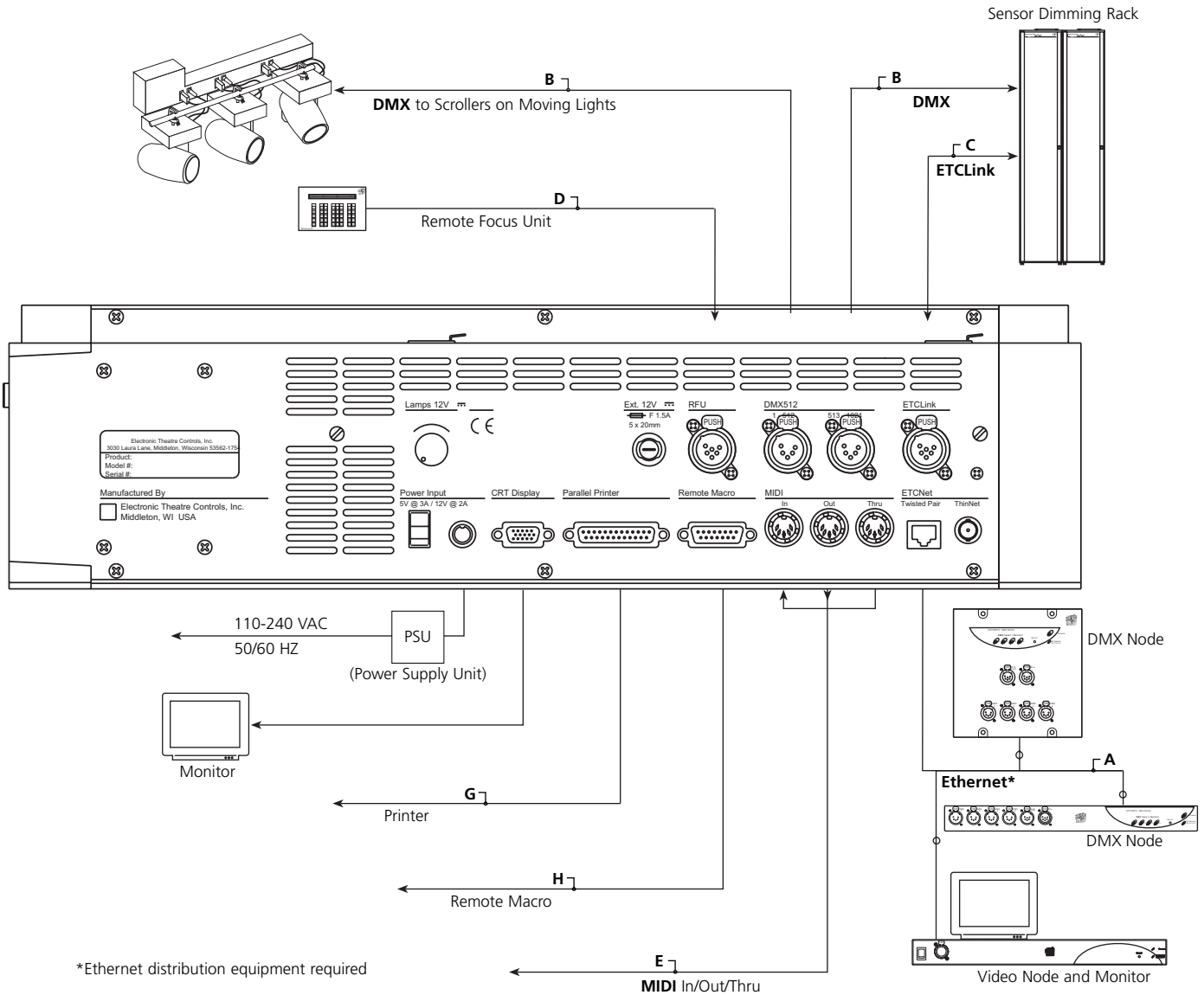

|                       |   |
|-----------------------|---|
| <b>INTERFACES</b>     | DMX512 Outputs (2)<br>Ethernet<br>ETCLink<br>MIDI<br>MIDI Show Control<br>MIDI Time Code<br>Remote Macro/Go<br>Remote Trigger<br>Remote Focus Unit  |
| <b>CONTROL KEYPAD</b> | Cue attributes<br>Cues from .1 to 999.9<br>Split up/down fade times<br>Wait times<br>Follow time<br>Link to cue or macro<br>Modified rate<br>8-part multipart cues<br>Selective cue recording<br>Channel Functions<br>Lists constructed with +, -, Except, And, Thru<br>Sneak sets channel to discrete or fader level in default/specified time.<br>Only and Except features for group and channel manipulation.<br>Channel Attribute Display<br>Independent channel capability<br>Last Action Channels<br>X/Y Link List<br>Moving Light Functions<br>Focus point<br>16-bit fade resolution<br>Pop-up displays<br>ML Patch<br>Group Functions<br>500 groups with labels<br>Any cue or submaster may be accessed as a group<br>Submaster Functions<br>10 pages of 24 submasters with labels, timing and rate attributes<br>Bump buttons may be enabled, disabled or solo<br>Range editing of submaster attributes in submaster list<br>Submasters may be individually changed between pile-on and inhibitive<br>Effect Functions<br>100 steps each<br>Step times<br>In/Dwell/Out step times<br>High/Low levels<br>In/Dwell/Out effect times<br>Effects may be recorded as cues and loaded to submasters.<br>Range editing of effect step values and attributes<br>Live effects recording<br>Macros<br>2,000 macros<br>Macros may activate any button on the console<br>Live Learn mode<br>Blind editing<br>Astronomical Time Clock<br>Program up to 500 events<br>Play back according, day of week, time of day or in reference to time before/after sunrise or sunset |

### CONSOLE CONNECTIONS

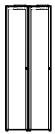

\*Ethernet distribution equipment required

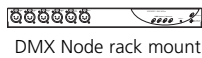
### Wire Types for Express consoles with....

| Device   | Wire Type  |                      |
|--|--|----------------------|
| <br>Sensor Racks        | <b>DMX</b> (XLR5)<br>(1) Belden 9729<br><b>ETCLink</b> (XLR6)<br>(1) Belden 9729<br>(2) #16 AWG Stranded | <b>B</b><br><b>C</b> |
| <br>Video Node          | <b>Category 5</b> Ethernet (RJ45)<br>(1) Belden 1583A (UTP)  | <b>A</b>             |
| <br>DMX Node rack mount | <b>Category 5</b> Ethernet (RJ45)<br>(1) Belden 1583A (UTP)  | <b>A</b>             |
| <br>DMX Node wall mount | <b>Category 5</b> Ethernet (RJ45)<br>(1) Belden 1583A (UTP)<br>(2) #16 AWG Stranded                      | <b>A</b>             |

| Device   | Wire Type  |          |
|--|--|----------|
| MIDI   | Standard <b>MIDI</b> Cables<br>5 Pin Din Connector               | <b>E</b> |
| <br>Remote Focus Unit | <b>RFU</b> (XLR6)<br>(1) Belden 9728<br>(2) #16 AWG Stranded     | <b>D</b> |
| DMX (In + Out)   | <b>DMX</b> (XLR5)<br>Belden 9729                                 | <b>B</b> |
| Printer - Parallel   | Standard Parallel Printer Cable                                  | <b>G</b> |
| Remote Macro   | DB 15<br>Consult Manual or ETC Technical Services<br>for details | <b>H</b> |

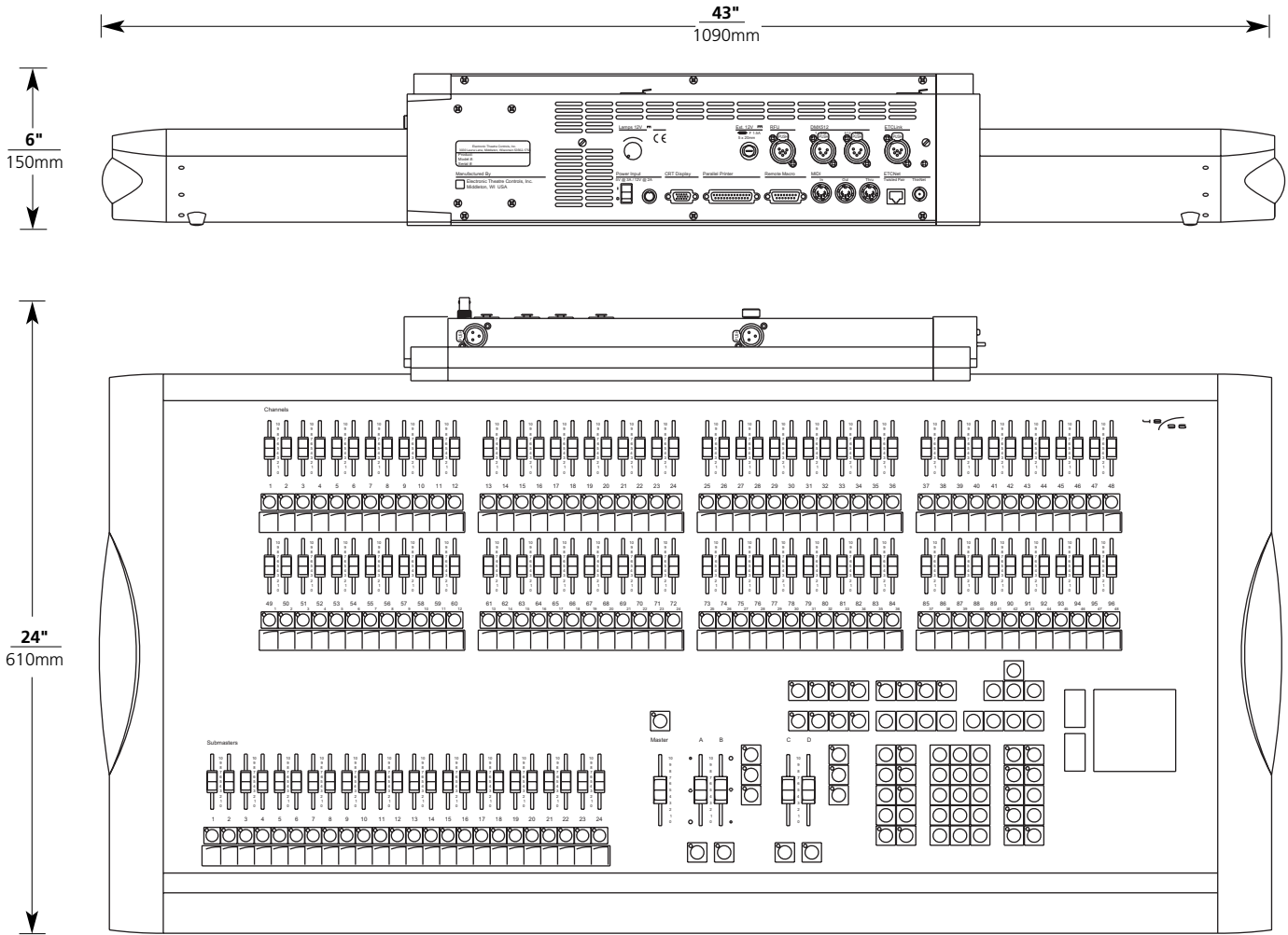

### DIMENSIONS

#### Express 48/96 Dimensions

| Model         | Height |     | Width  |      | Depth  |     |
|---------------|--------|-----|--------|------|--------|-----|
|               | inches | mm  | inches | mm   | inches | mm  |
| Express 48/96 | 6.0    | 150 | 43.0   | 1090 | 24.0   | 610 |

#### Express Accessories Dimensions

| Model             | Height |     | Width  |     | Depth  |     |
|-------------------|--------|-----|--------|-----|--------|-----|
|                   | inches | mm  | inches | mm  | inches | mm  |
| Express LPC       | 1.8    | 45  | 17.0   | 432 | 12.5   | 320 |
| DMX Node - rack   | 1.8    | 45  | 17.0   | 432 | 12.5   | 320 |
| DMX Node -wallbox | 8.0    | 203 | 8.0    | 203 | 4.1    | 105 |
| Remote Focus Unit | 1.4    | 34  | 8.5    | 250 | 5.5    | 140 |
| Video Node        | 1.8    | 45  | 17.0   | 432 | 12.5   | 320 |

### WEIGHTS

#### Express 48/96 Weights

| Model         | Weight |      | Shipping Weight |      |
|---------------|--------|------|-----------------|------|
|               | lbs    | kgs  | lbs             | kgs  |
| Express 48/96 | 35.0   | 15.8 | 42.0            | 19.0 |

#### Express Accessories Weights

| Model             | Weight |     | Shipping Weight |     |
|-------------------|--------|-----|-----------------|-----|
|                   | lbs    | kgs | lbs             | kgs |
| Express LPC       | 11.0   | 5.0 | 18.3            | 8.3 |
| DMX Node - rack   | 8.0    | 3.6 | 18.0            | 8.2 |
| DMX Node -wallbox | 2.2    | 1.0 | 10.0            | 4.5 |
| Remote Focus Unit | 3.0    | 1.4 | 5.0             | 2.3 |
| Video Node        | 8.0    | 3.6 | 18.0            | 8.2 |



**Corporate Headquarters** ■ 3031 Pleasant View Rd, PO Box 620979, Middleton WI 53562 0979 USA ■ Tel +1 608 831 4116 ■ Fax +1 608 836 1736  
**London, UK** ■ Unit 26-28, Victoria Industrial Estate, Victoria Road, London W3 6UU, UK ■ Tel +44 (0)20 8896 1000 ■ Fax +44 (0)20 8896 2000  
**Rome, IT** ■ Via Ennio Quirino Visconti, 11, 00193 Rome, Italy ■ Tel +39 (06) 32 111 683 ■ Fax +39 (06) 32 656 990  
**Holzkirchen, DE** ■ Ohmstrasse 3, 83607 Holzkirchen, Germany ■ Tel +49 (80 24) 47 00-0 ■ Fax +49 (80 24) 47 00-3 00  
**Hong Kong** ■ Room 605-606, Tower III Enterprise Square, 9 Sheung Yuet Road, Kowloon Bay, Kowloon, Hong Kong ■ Tel +852 2799 1220 ■ Fax +852 2799 9325  
**Web** ■ www.etcconnect.com ■ Copyright © 2006 ETC. All Rights Reserved. All product information and specifications subject to change. 4110L1019 Rev. D Printed in USA 07/06